

LTE mobile network

Hakim MABED, UBFC

Why LTE ? 3 objectives and 1 constraint

- Higher throughput and more throughput flexibility
 - Consequence: more frequency band, i.e. higher frequency carrier
- Simplification of network architecture to reduce transfer latency
 - Consequence: less equipment i.e. less CAPEX (Capital expenditure)
- Simplification of network maintenance by network auto-tuning
 - Consequence: more software driven decisions i.e. less OPEX (Operating expenditure)
- Billions of € in 23G networks
 - Constraint: need full compatibility with old networks and 234G UE

3GPP Collaboration

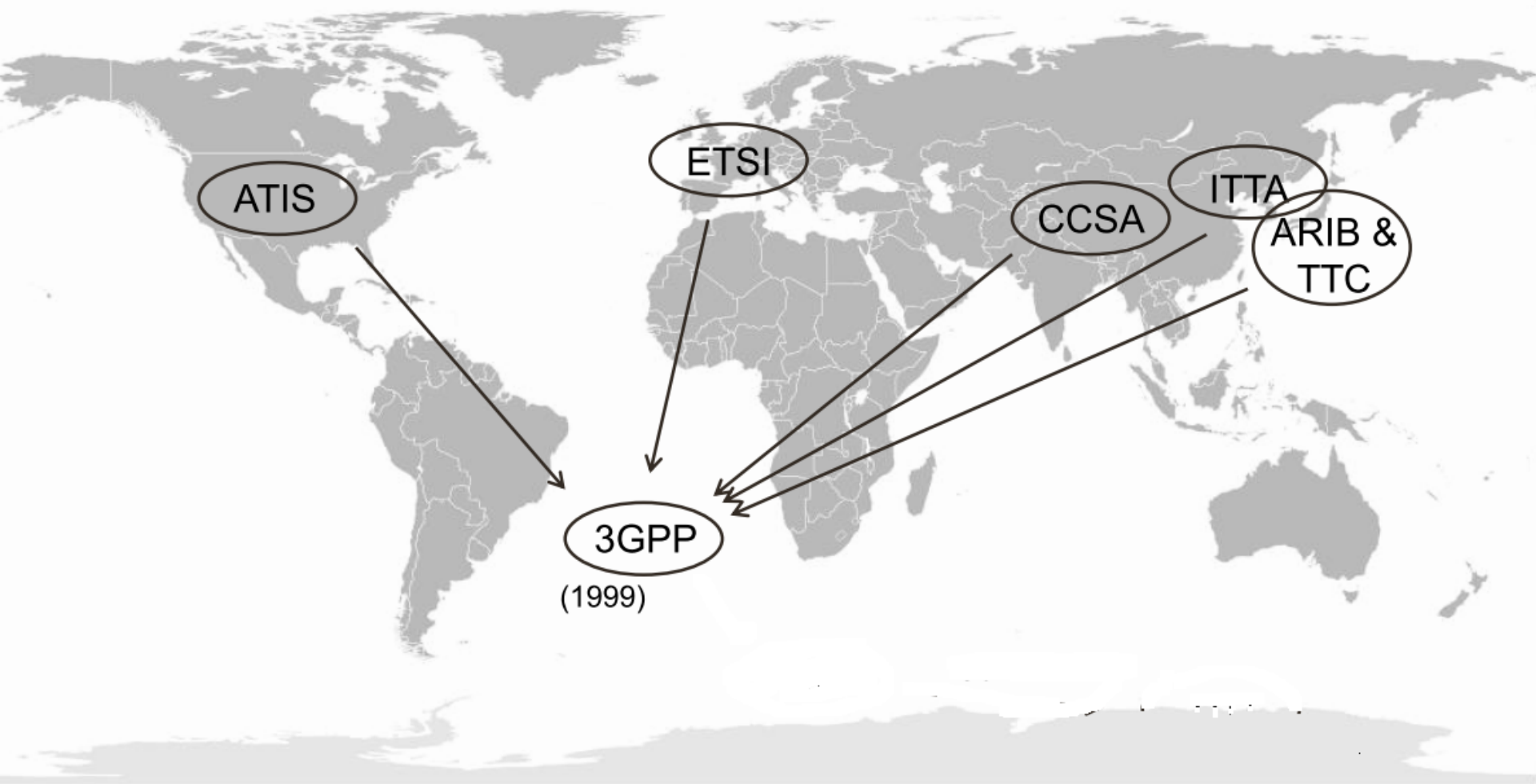

3GPP Collaboration

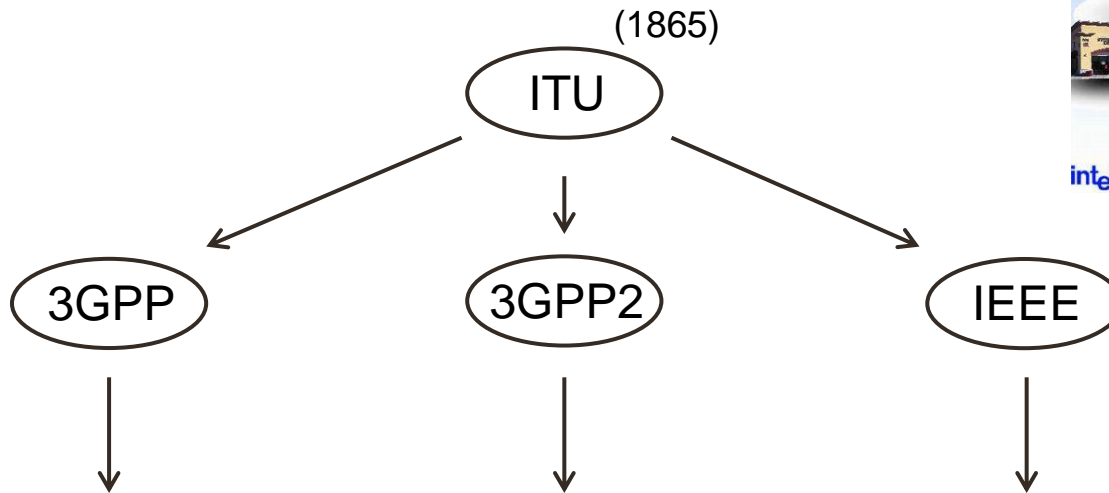

- | | | | | | |
|--------|------------|--------|-----------|--------|-------|
| (1991) | GSM | (2004) | CDMA-2000 | (2001) | WIMAX |
| (2001) | UMTS | | | | |
| (2002) | HSDPA | | | | |
| (2008) | LTE | | | | |

■ ITU: International Telecommunications Union

- Manage intl. radio frequency spectrum
- Ensures effective use of spectrum
- Defines technologies & standards

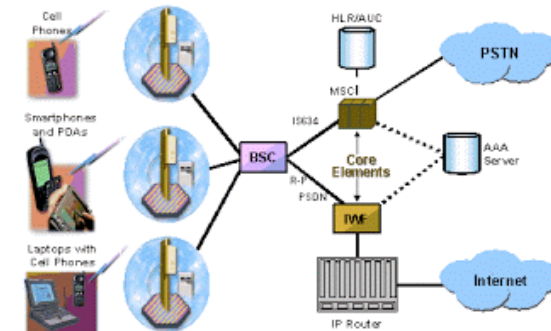

3GPP Releases

Version	Date	Info from 3GPP: 3rd Generation Partnership Project
Release 98	1999 Q1	specified EDGE 3G layer on GSM network (2Mbps → 348kbps)
Release 99	2000 Q1	specified the 1 st version of UMTS, incorporating a CDMA air interface
Release 00	2001 Q2	added all-IP Core Network
Release 5	2002 Q1	introduced IP Multimedia Subsystem and HSDPA (14Mbps)
Release 6	2004 Q4	integrated operation with Wireless LAN networks and added HSUPA, MBMS, enhancements to IMS. NTT Docomo suggests to study a new IMT standard. 3GPP LTE study starts in 2005.
Release 7	2007 Q4	decreasing latency, improvements to QoS and VoIP real-time applications, HSPA+ , NFC (mobile payments), EDGE Evolution. (28Mbps)
Release 8	2008 Q4	1 st LTE release. All-IP Network (SAE), new OFDMA, FDD and MIMO based radio interface
Release 9	2009 Q4	SAE Enhancements, WIMAX and LTE/UMTS Interoperability
	2009 Dec.	1 st commercial network in Norway/Sweden by TeliaSonera (data transfer with Samsung USB modem)

3GPP Releases

Version	Date	Info from 3GPP: 3rd Generation Partnership Project
Release 10	2011 Q1 2011 Feb.	All 3GPP LTE advanced fulfilled, 100Mbps for moving UE and 1Gbps for fixed UE 1 st LTE worldwide Smart Phone (Samsung Galaxy Indulge)
Release 11	2012 Q3	Service layer interconnection between national operators
	2013 Jun. 2013 Oct.	1 st LTE-A of Galaxy S4 by Samsung 1 st LTE-A in France (Marseille by SFR), 174Mbit/s DL
Release 12	2014 Q2	Finished in March 2015 (emergency and security services)
Release 13	2016 Q1	LTE enhancements for Machine-Type Communication. Elevation Beamforming / Full-Dimension MIMO, Indoor positioning.
Release 14	Planned for June 2017	Energy Efficiency, Location Services (LCS), Mission Critical Data over LTE, Mission Critical Video over LTE, Multimedia Broadcast Supplement for Public Warning System (MBSP), massive Internet of Things
Release 15	Planned for Sept 2018	Support for 5G Vehicle-to-x service, Future Railway Mobile Communication System
		Smart orientable antennas ?

LTE Speed

- DL speed up to 300Mbps
- UL 75Mbps
- Supports moving at 350km/h → and up to 500km/h
- 5ms latency for handover
- Serves +200 clients simultaneously
- Several cell sizes (300m → 100km)

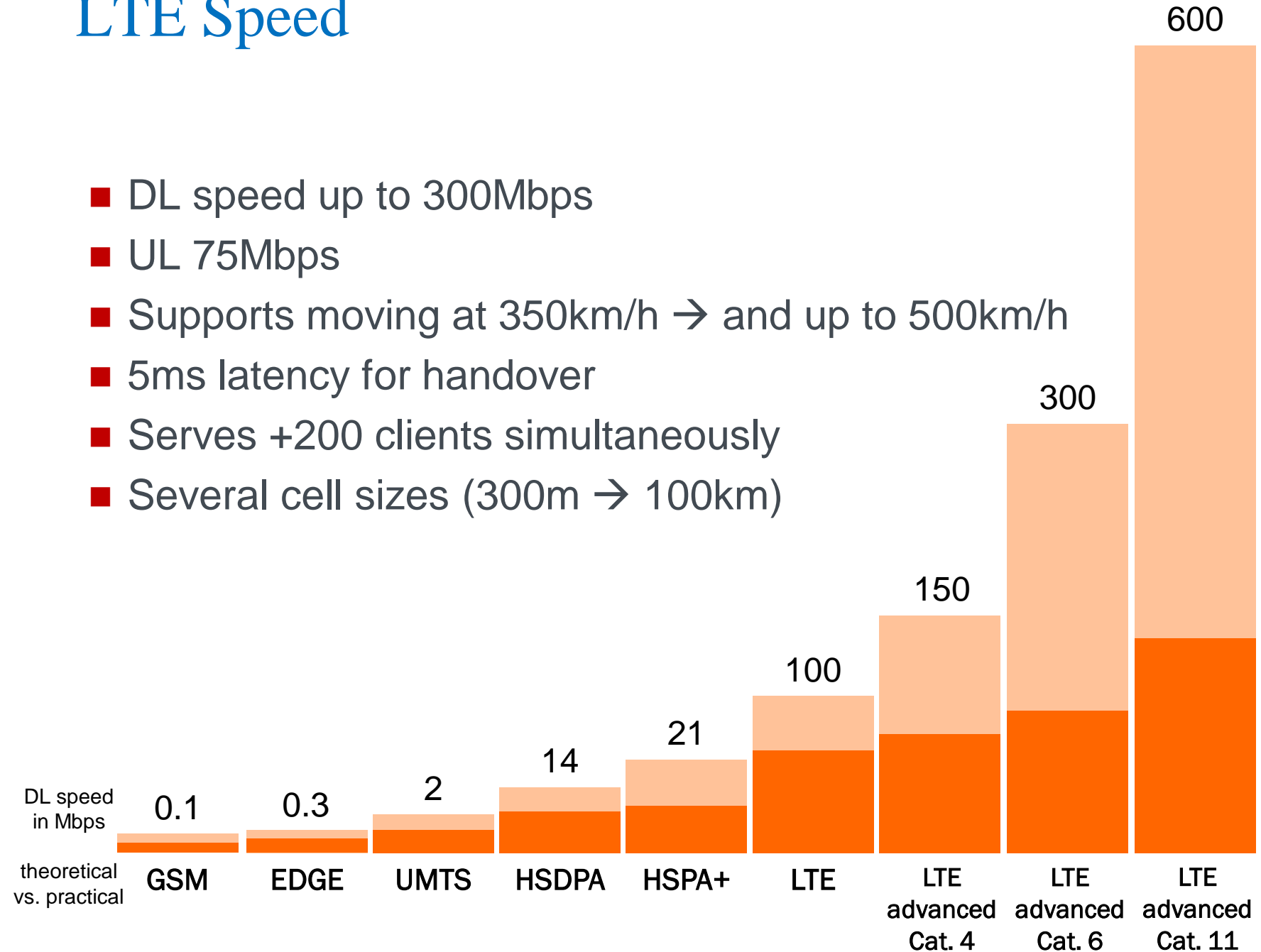

LTE Country Map (Feb. 2014)

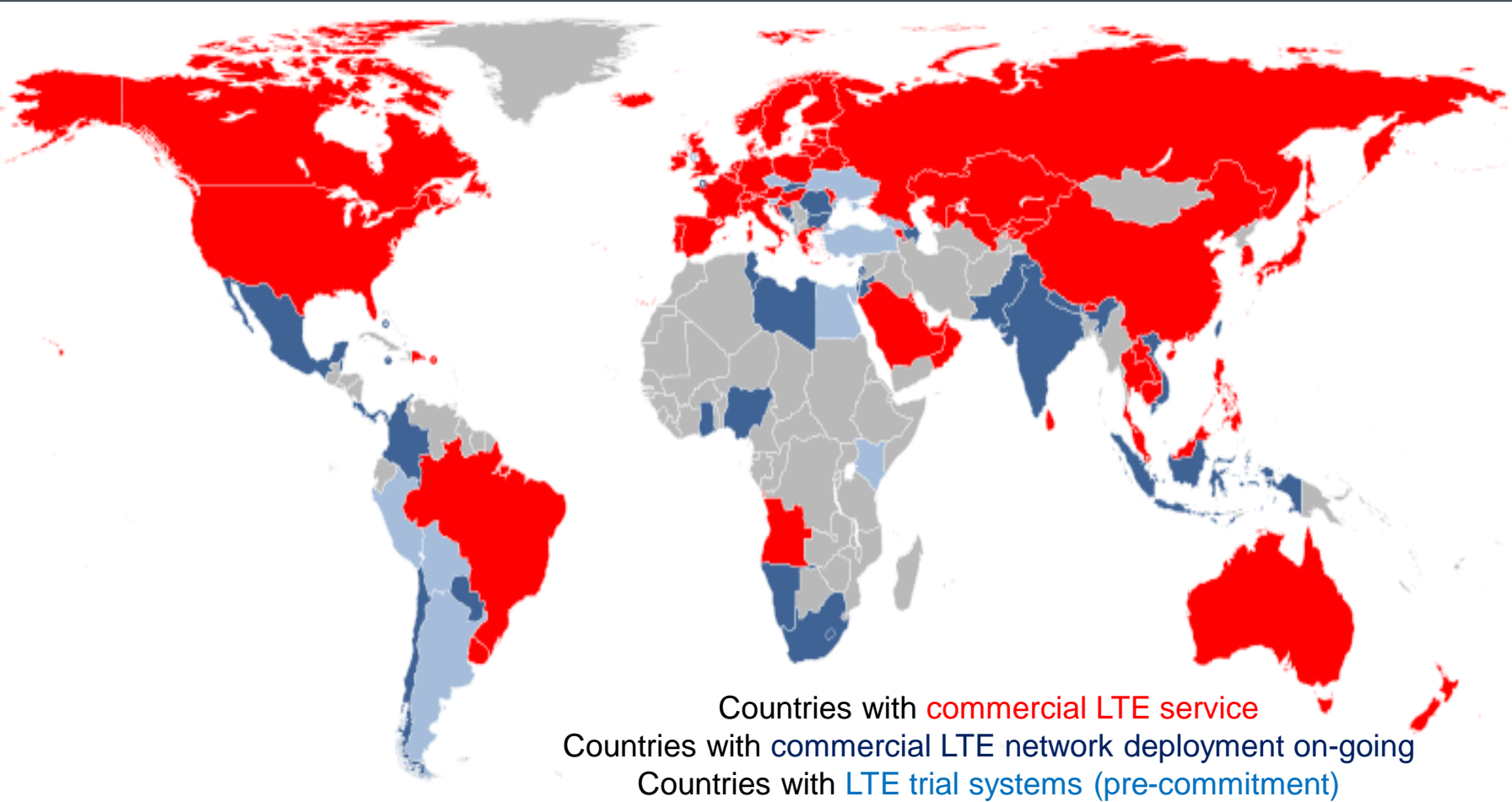

LTE deployment in the world (Feb. 2018)

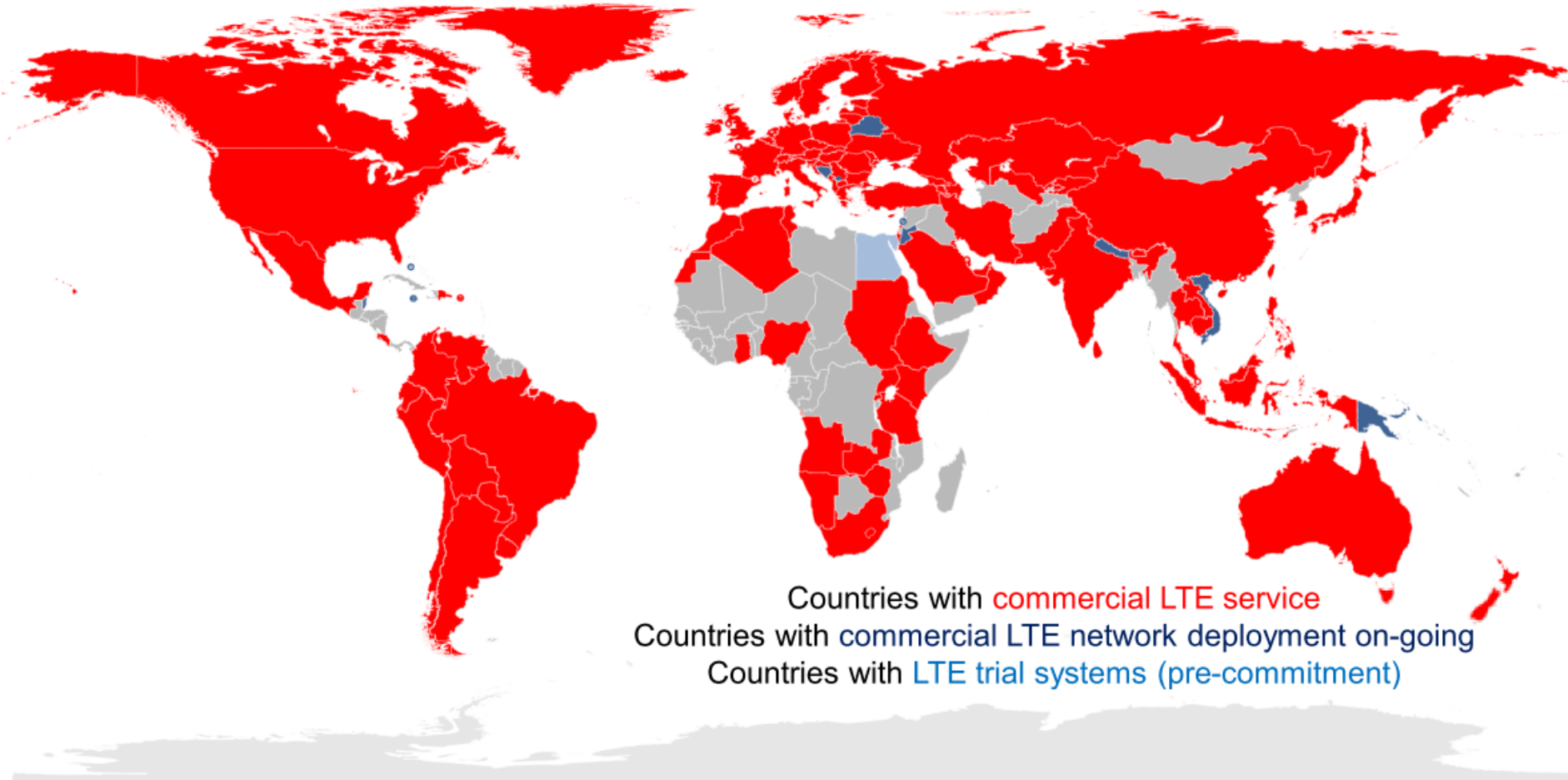

Agenda

- Architecture global view
- LTE frequency domain technologies
- LTE time domain technologies
- Convergence of time and space
- LTE protocol architecture
 - Packet Data Convergence Protocol layer
 - Radio Link Control layer
 - Medium Access Control layer
- Resource Allocation

LTE Network architecture

- LTE network is composed of two parts: eUTRAN and EPC
- eUTRAN = Evolved Universal Terrestrial Radio Access Network
 - Radio part of the LTE network
 - Ensure connection between UEs and the network operator core via UHF
 - Is composed of radio antennas, bases stations (eNodeB) and wire network
- EPC = Evolved Packet Core
 - Based on IP identification for transmitting voice / data packets and signalization
 - Allows interconnection with distant eNodeB, other providers networks, wire network and Internet

LTE Network architecture: eUTRAN

- Uses IP protocol to transfer packets
 - Uses several bandwidth given by the network operator (1.4, 3, 5, 10, 15, 20MHz)
 - Emits at several given frequencies (800MHz, 1800MHz, 2600MHz)

- Mainly composed of eNodeB stations to cover all geographical territory

- Uses two kind of interfaces (S1 and X2)
- S1 interface links the eUTRAN with EPC
 - S1-MME for signalization and control with EPC
 - S1-U for data flows
- X2 interface links the eNodeB between them (for handover purposes, future Wi-Fi service, etc.)

LTE Network architecture: EPC

- Is composed of several sub-parts:
- MME = Mobility Management Entity
 - Involved in the activation/deactivation process and also responsible for choosing the SGW for a UE at the initial attach
 - Responsible for authenticating the user (by interacting with the HSS)
- SGW = Serving Gateway
 - Routes user data packets
 - Acts as the mobility anchor for the user plane during inter-eNodeB handovers
 - Acts as the anchor for mobility between LTE and other 3GPP technologies
- HSS = Home Subscriber Server
 - Contains user-related and subscription-related information
 - Mobility management, call and session establishment support, user authentication and access authorization

LTE Network Architecture

Architecture
→ Global view

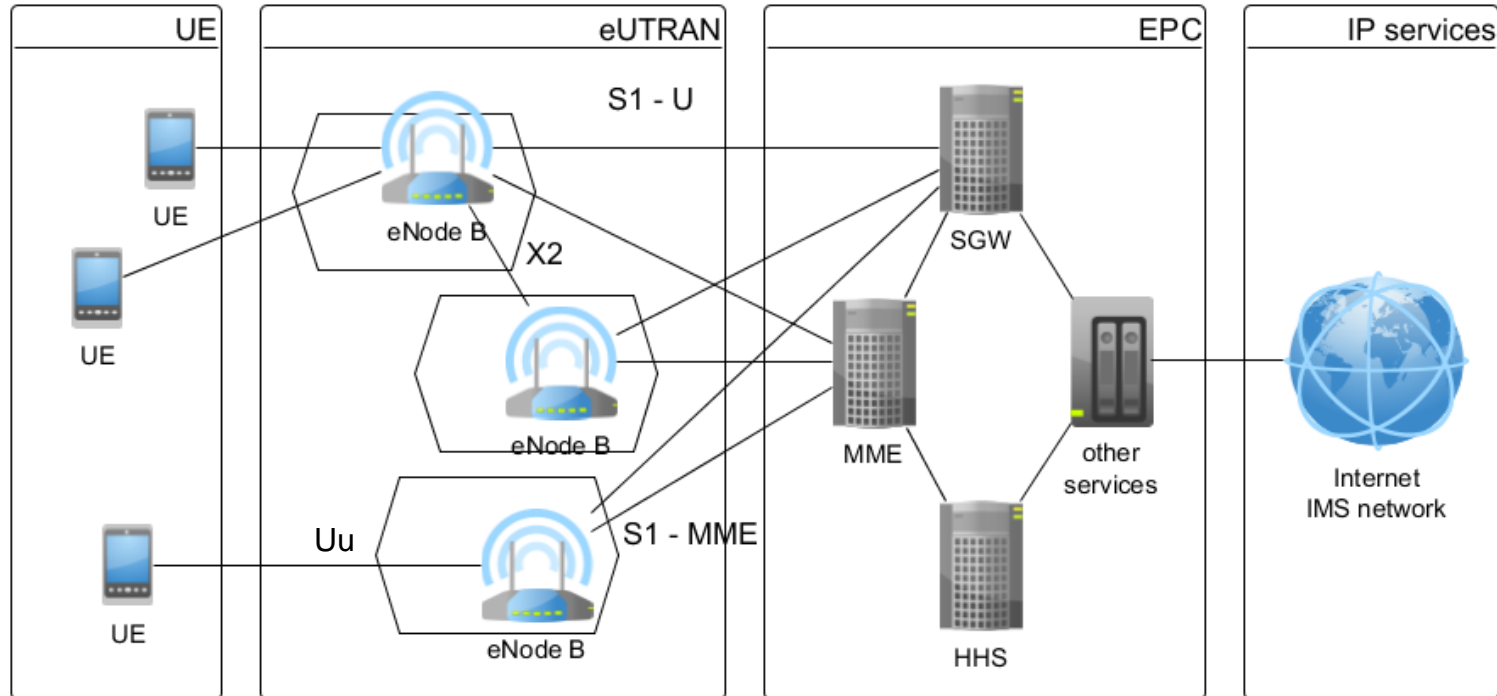

SGW (Serving Gateway)
MME (Mobility Management Entity)
HSS (Home Subscriber Server)

Agenda

- Architecture global view
- LTE frequency domain technologies
- LTE time domain technologies
- Convergence of time and space
- LTE protocol architecture
 - Packet Data Convergence Protocol layer
 - Radio Link Control layer
 - Medium Access Control layer
- Resource Allocation

LTE Physical Layer

- What influenced the frequency technologies of LTE?
- The design of LTE physical layer (PHY) is influenced by original requirements
 - High peak transmission rate (100Mbps Downlink/50Mbps Uplink)
 - Spectral efficiency
 - Multiple channels bandwidth (1.4 to 20MHz)
- OFDM technology was selected
 - Created in the 60's
 - Suffered lack of electronic technology
 - Mature technology now (used for Wi-Fi, Wimax)

Frequency Division Multiplexing

- 1966: R.W. Chang, Bell Labs: O-FDM paper and patent
- Used in DAB (1995), Wi-Fi 802.11a/n (1999), DVB-T/H and VDSL (2004)
- FDM splits the channel bandwidth into multiple subcarriers transmitted simultaneously to the receiver.
- Each frequency channel carries a separate signal. These sub-bands can be used independently with completely different information streams (2G, 200kHz), or **used dependently in the case of information sent in a parallel stream (4G, 15kHz)**.

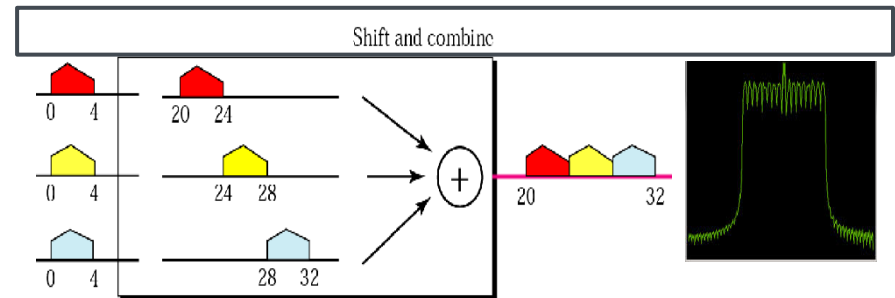
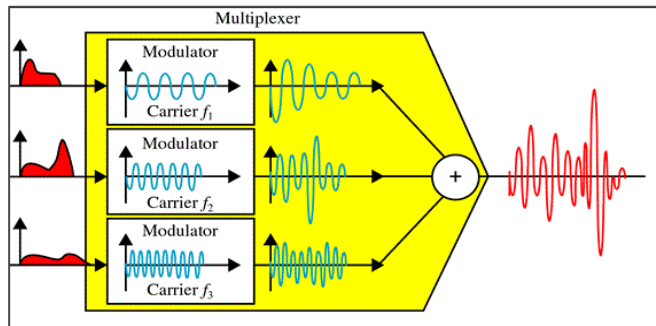

- LTE uses very small subcarrier, so low throughput per channel
 - Advantages: efficient handling of multipath interference and robustness against narrowband interference
 - Drawbacks: sensitivity to frequency offset and phase noise and a high peak-to-average power ratio (PAPR) that reduces the power efficiency of the RF amplifier at the transmitter: sometimes it needs more power than the mean power for which the transmitter is defined => problem for the UE on UL !

Frequency Division Multiplexing

- 1966: R.W. Chang, Bell Labs: O-FDM paper and patent
- Used in DAB (1995), Wi-Fi 802.11a/n (1999), DVB-T/H and VDSL (2004)
- FDM splits the channel bandwidth into multiple subcarriers transmitted simultaneously to the receiver.
- Each frequency channel carries a separate signal. These sub-bands can be used independently with completely different information streams (2G, 200kHz), or **used dependently in the case of information sent in a parallel stream (4G, 15kHz).**

2

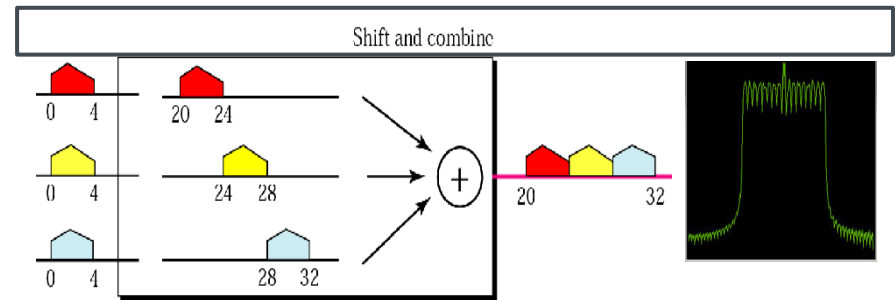
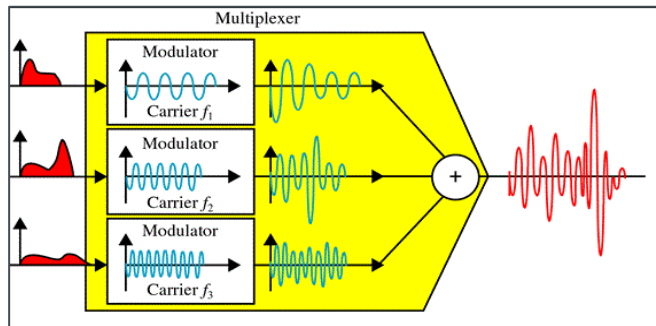

- LTE uses very small subcarrier, so low **1** output per channel
 - Advantages: efficient handling of multipath interference and robustness against narrowband interference
 - Drawbacks: sensitivity to frequency offset and phase noise and a high peak-to-average power ratio (PAPR) that **3** reduces the power efficiency of the RF amplifier at the transmitter: sometimes it needs more power than the mean power for which the transmitter is defined => problem for the UE on UL !

FDM technology

- “Small subcarriers means low throughput per channel”

1

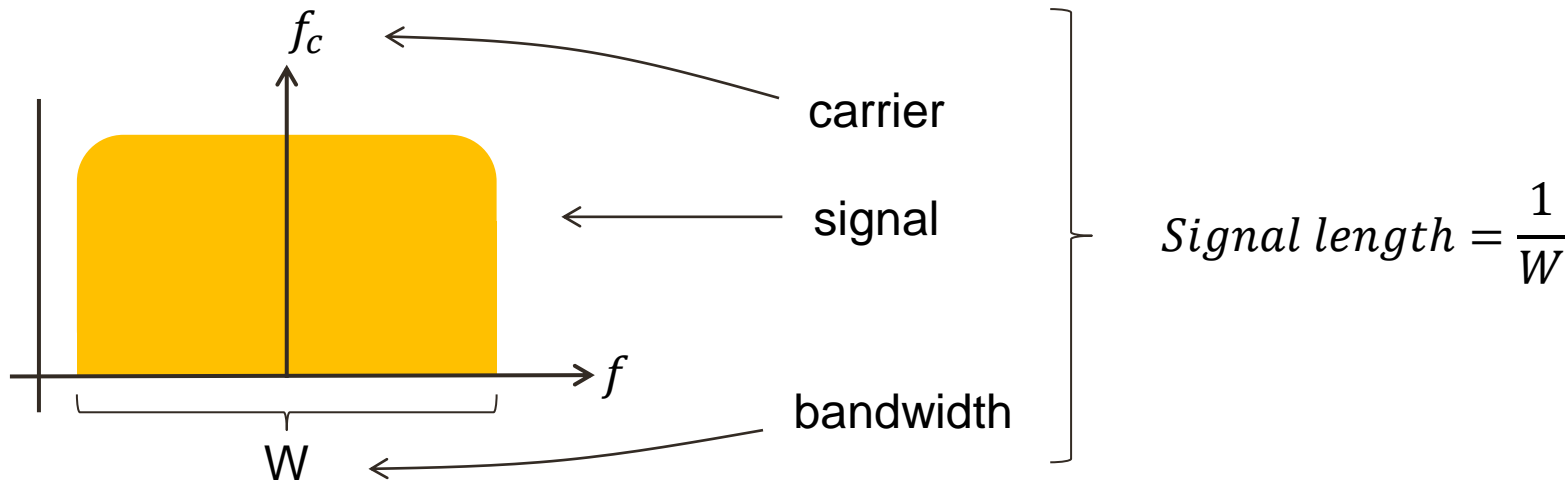

With $W = 180\text{kHz}$, signal length $= \frac{1}{180} = 5.5\mu\text{s}$

With $W = 15\text{kHz}$, signal length $= \frac{1}{15} = 66.7\mu\text{s}$

Same message, but
different transmission
times → different
throughputs

- We can also write: Symbol rate $= f_s = \Delta_f \cdot FFT\ size$

FDM technology

- “Small subcarriers means low throughput per channel”

1

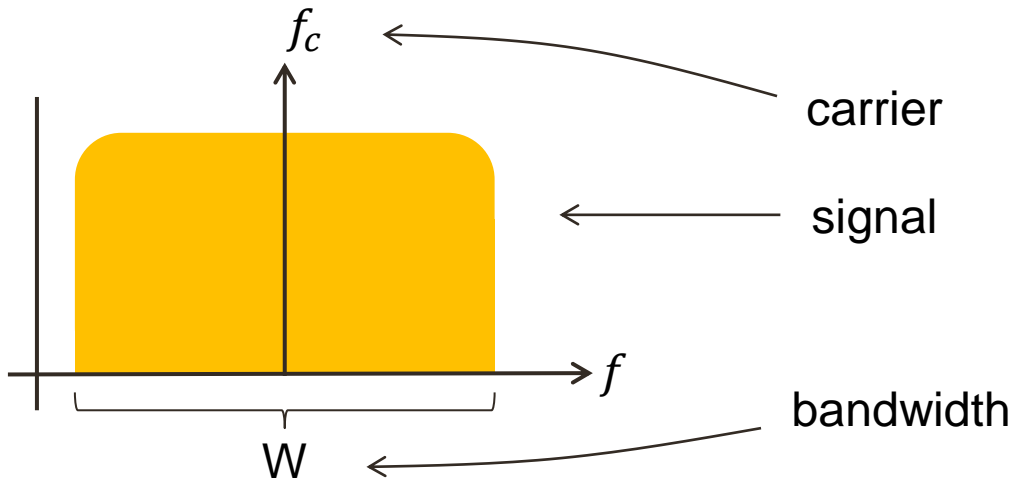

$$\text{Signal length} = \frac{1}{W}$$

With $W = 180\text{kHz}$, signal length $= \frac{1}{180} = 5.5\mu\text{s}$

With $W = 15\text{kHz}$, signal length $= \frac{1}{15} = 66.7\mu\text{s}$

Same message, but
different transmission
times

- We can also write: Symbol rate $= f_s = \Delta_f \cdot \text{FFT size}$

?

FDM technology

- “Each frequency channel carries a separate signal”

2

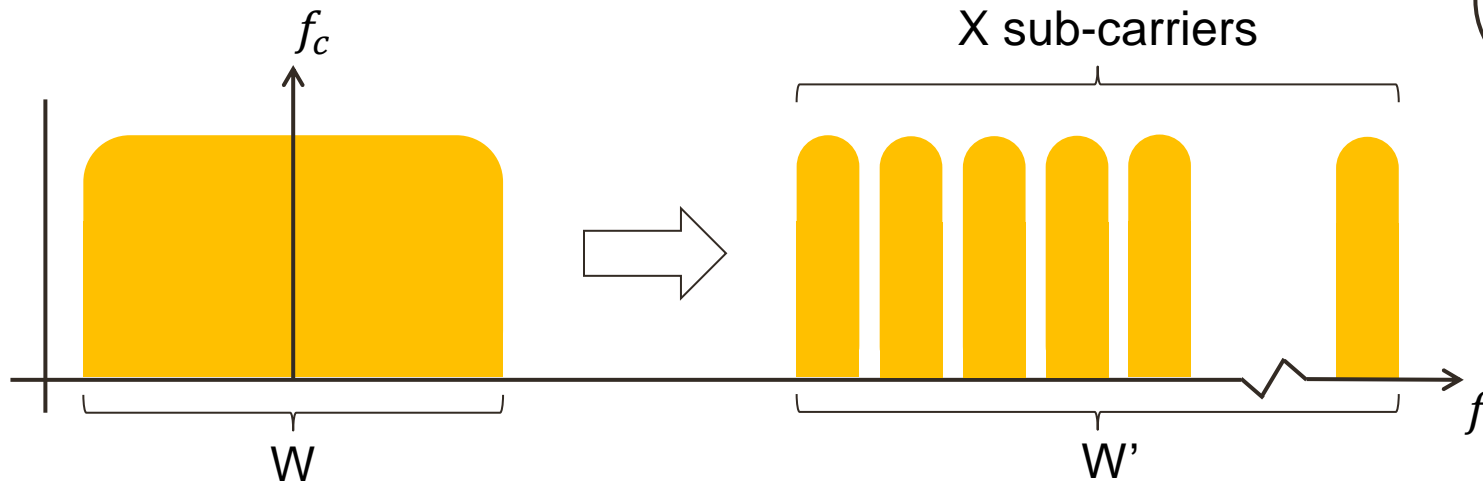

- To achieve same throughput (information per seconds) we can increase the number of sub-carriers
- The X sub-carriers resulting signal is given using a Fourier transform

Time series sample

Frequency samples

$$x(n) = \frac{1}{N} \sum_{k=0}^{N-1} x(k) \cdot e^{i2\pi kn/N}$$

Number of samples

FDM technology

2

Each sub-carrier
(at a given
frequency) is a
sinusoid signal

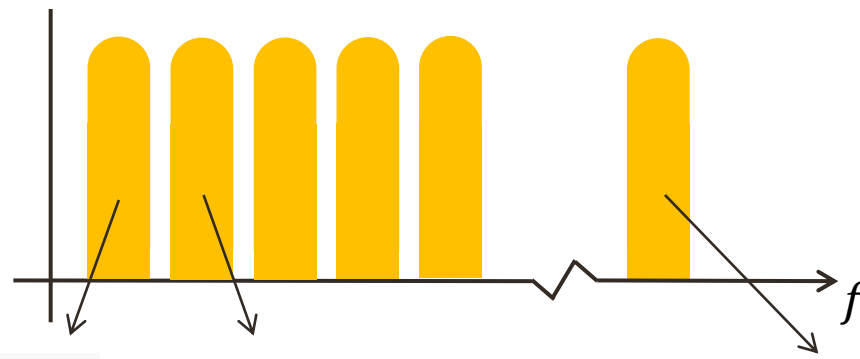

In this example,
the signals are
classic sin(x)
waves, but it can
vary in phase
and amplitude
(see modulation
scheme)

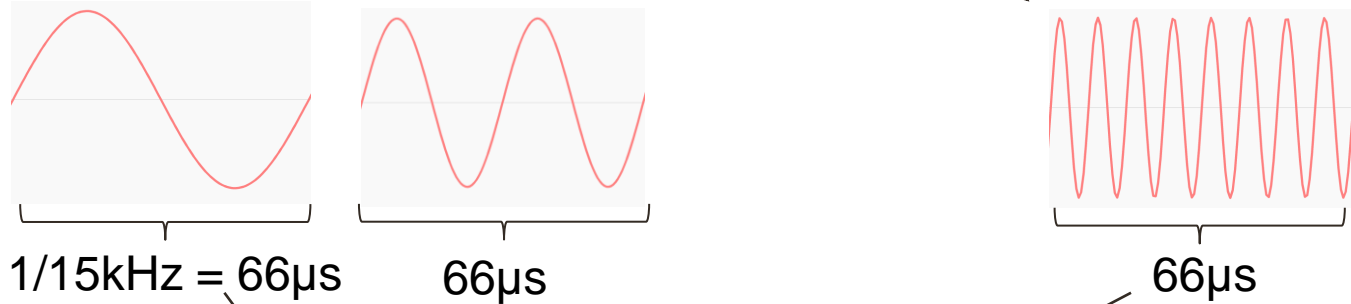

We use a Fourier
transformation
(IFFT here) to
compose the
resulting signal

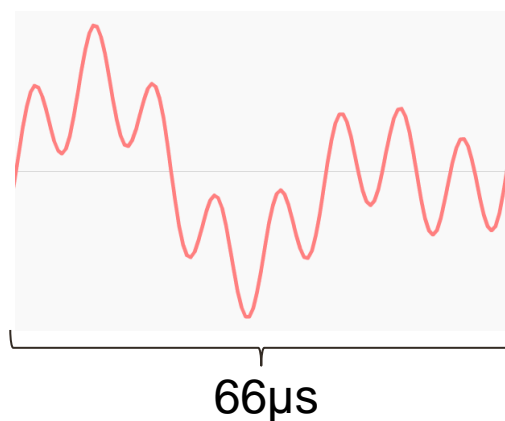

$$x(n) = \frac{1}{N} \sum_{k=0}^{N-1} x(k) \cdot e^{i2\pi kn/N}$$

FDM technology

3

- “High peak-to-average power ratio (PAPR) ”
 - Each sub-carrier is encoded separately (amplitude and phase may vary)
 - Sub-carrier sum (IFFT) may result in high power peaks

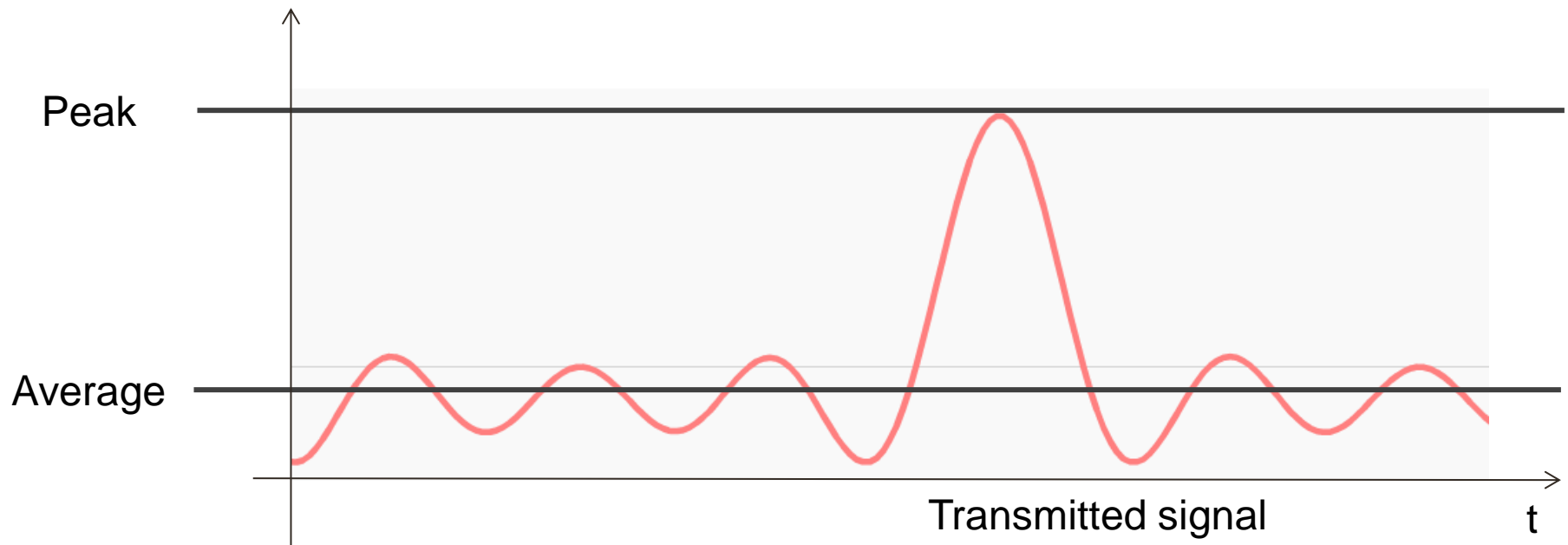

OFDM technology

- OFDM = Orthogonal Frequency Division Multiplexing
- The sub-carriers signals are orthogonal to each other
 - Each sub-carrier is modulated with own modulation scheme (QAM, PSK)
- The information data stream is parallelized and spread across the sub-carriers for transmission
- Modulating data symbols is equivalent to IFFT (Inverse Fast Fourier Transform)
 - This operation gives an OFDM symbol of duration T_u
- In the receiver a FFT is used to demodulate the symbols and get the data stream back

OFDM technology

■ FDM (2G, 3G)

- Simple frequency division multiplex
- The total available bandwidth is divided into a series of non-overlapping frequency sub-bands
- The occupied bandwidth W is function of the number of carriers N :
 $W = N \cdot 2 \cdot \text{data_rate}$

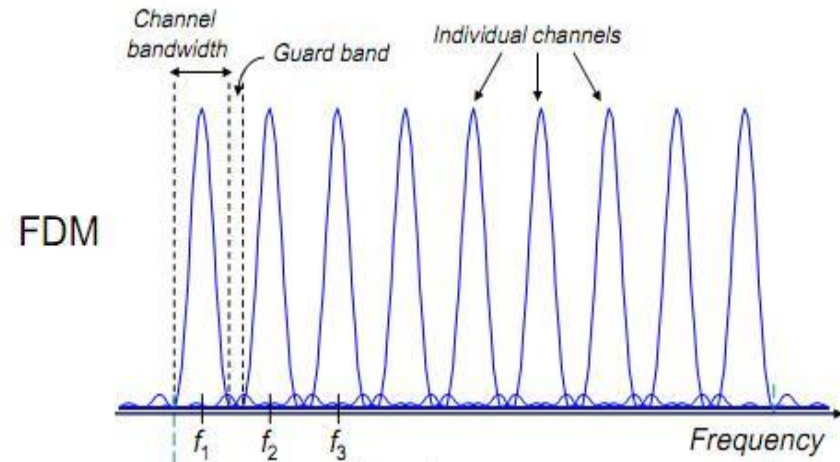

■ OFDM (4G)

- Spectral overlapping among subcarriers is allowed
- The carriers are made orthogonal by appropriately choosing the frequency spacing between them to ensure the OFDM subcarriers separation by the RX
- The occupied bandwidth W is reduced

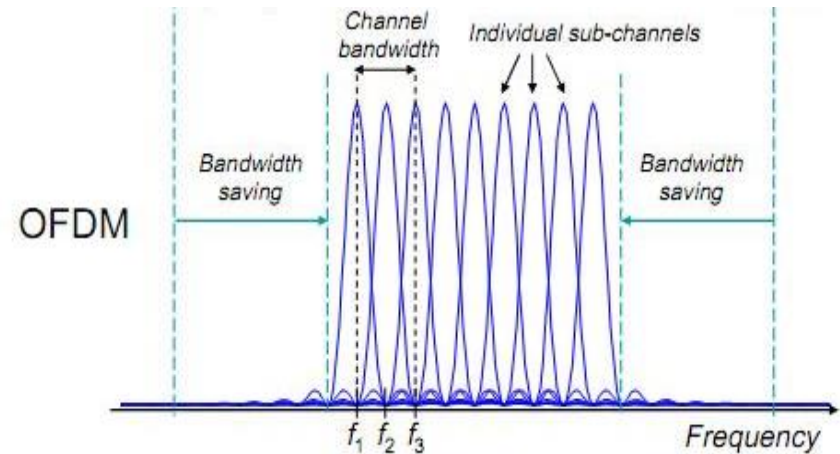

OFDM technology

- OFDM requires very accurate synchronization between the receiver and the transmitter
- Multiple replicas of a transmitted signal are received with various time delays due to multipath between the transmitter and receiver
 - A Cyclic prefix (CP) is added at the beginning of the OFDM symbol to prevent an overlapping of symbols
- CP is a duplication of a fraction of the symbol end
 - The total OFDM symbol length becomes

$$T_s = T_u + CP$$
 - This makes the OFDM symbol insensitive to time dispersion

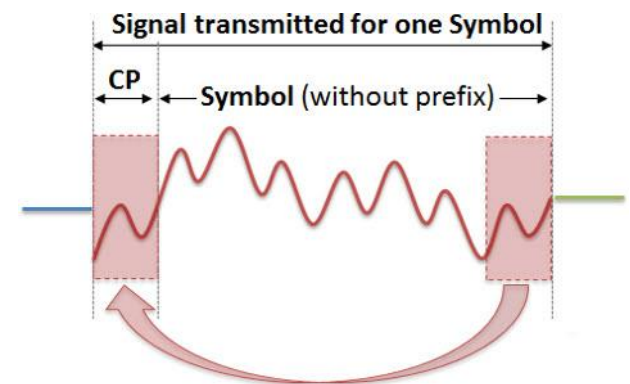
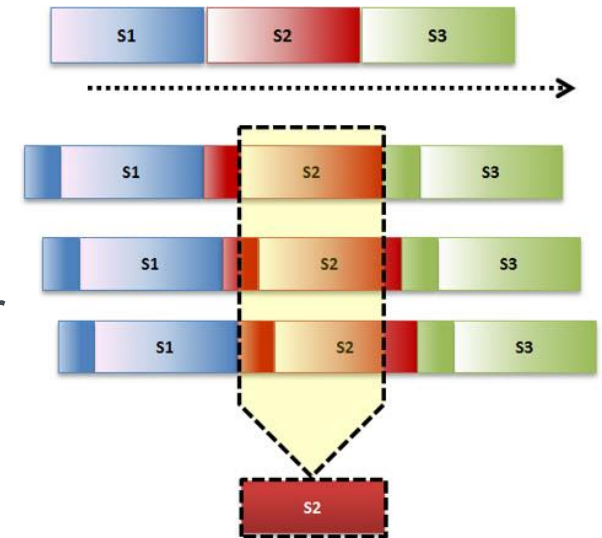

<http://www.telecomhall.com>

From OFDM to OFDMA

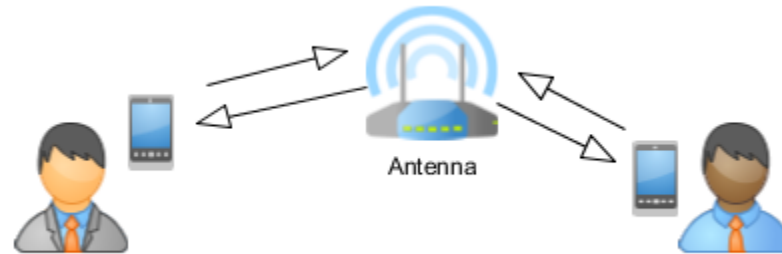

- How to speak and listen at the same time ?
 - Achieving a 2-way communication over the same channel is called duplexing
 - Half-duplexing vs. full duplexing

- FDD = Frequency Division Duplex
 - Full duplexing
 - Uses two separated channels (frequencies) to communicate on DL and UL

- TDD = Time Division Duplex
 - Half-duplexing
 - Shares the same channel to carry DL and UL information
 - Information is sent at different time slots, requires strong synchronization
 - Guard band between bursts

From OFDM to OFDMA

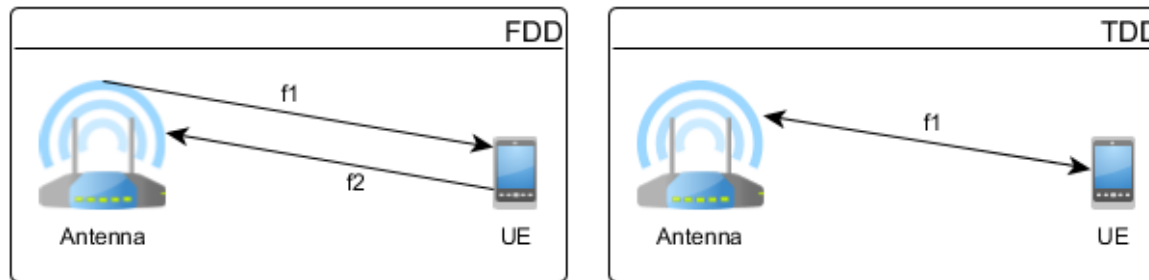

■ How to choose a system ? Take into consideration:

- Spectral efficiency
- Unbalanced traffic
- Distance preferability
- Equipment costs
- Low latency
- MAC layer complexity

	FDD	TDD
Pros	- No time delay	- No duplexer needed (low cost) - Adaptability to users demands
Cons	- Need to buy frequency bandwidth (expensive) - Low spectral efficiency	- Augmentation of guard band with distance - Difficult to synchronize in time

OFDMA technology

- OFDMA = Orthogonal Frequency Division Multiple Access
 - Multi-users version of OFDM encoding method
- Multiplex traffic by allocating specific patterns of sub-carriers in the time-frequency space to different users
 - Sub-carriers have small bandwidth (15kHz)
- Control channels and reference symbols can be included
 - Control channels carry information on the network and cells
 - Reference symbols assist in determining the propagation channel response
- Drawbacks
 - High sensitivity to frequency offset (instability of electronic equipment and Doppler effect)
 - High peak-to-average power ratio (PAPR = 12dB)
- Complicated methods can be used to overcome these problems but they are too expensive for UE
 - → UE needs another method for UL

SC-FDMA technology

- SC-FDMA = Single-Carrier Frequency Division Multiple Access
- Assigns a unique larger sub-carrier to individual users (~60kHz)
 - Actually uses frequency and time division
 - We have to deal with shorter symbols
- Sub-carriers are also orthogonal (due to frequency guard band)
- The required power is low, thus this technology is used for uplink
 - PAPR ~4dB

Differences between OFDMA and SC-FDMA

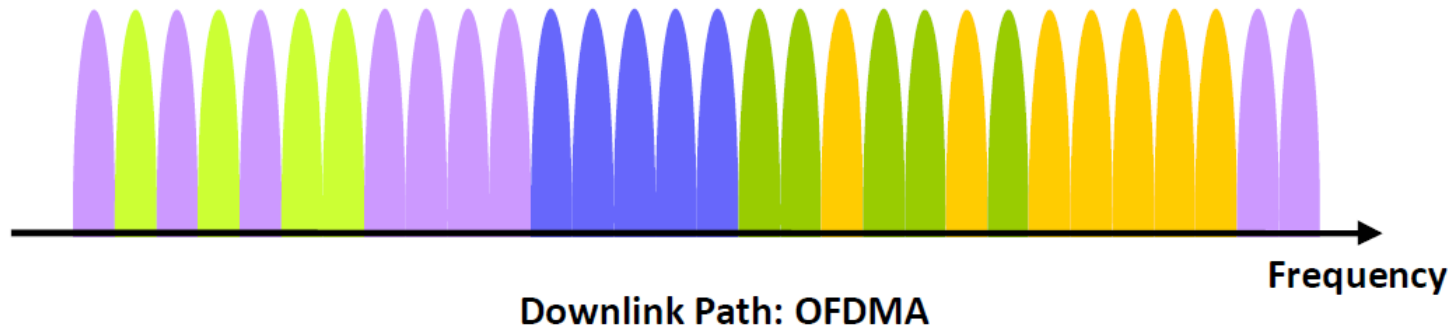

©2010 Telesystem Innovations Inc.

LTE usage of OFDM technology

- What is the impact of choosing OFDM technology on the LTE physical layer?

- Several bandwidths allocated
 - 27 in FDD, 11 in TDD mode
- OFDMA on Downlink (DL)
 - Sending information on several sub-carriers
 - Sub-carriers signals are orthogonal to each other
- SC-FDMA on Uplink (UL)
 - Assigns a unique larger sub-carrier to individual users
 - Uses frequency and time division
- Antennas are in MIMO mode
 - in MIMO case multiple antennas are used
 - MIMO system delivers higher data rate due to transmission of multiple data symbols simultaneously using multiple antennas

LTE specifications: Downlink sub-carriers

- Sub-carrier = allocated frequency
- In LTE, sub-carriers are separated by 15kHz
- It exists several bandwidth that can be used for LTE (1.4, 3, 5, 10, 15, 20MHz)
- The total number of sub-carriers available is limited by each bandwidth
 - Not all sub-carriers are used (e.g. DC sub-carrier and sides of bandwidth)

BW (MHz)	1.4	3	5	10	15	20
SubC Theoretical	$1400/15 = 93$	200	333	666	1000	$20000/15 = 1333$
SubC Practical	72	180	300	600	900	1200

LTE Architecture: Sub-carriers

- For the maximum bandwidth of 20MHz there are 1200 sub-carriers
- Sub-carriers == orthogonal frequencies separated
 - with $\Delta f = 15\text{kHz}$

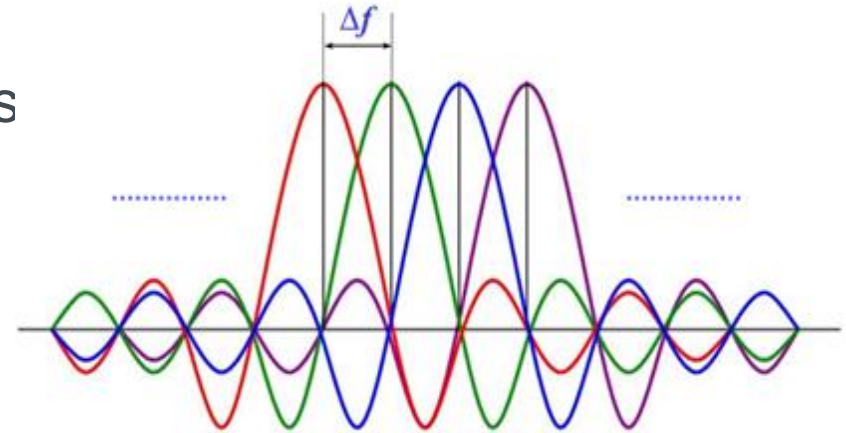

©2010 Telesystem Innovations Inc.

- Each sub-carrier is encoded with a specific modulation scheme
 - 1 symbol on the sub-carrier = x bits
- Several modulation schemes
 - BPSK → 1 bit (GSM)
 - QPSK (~~4-QAM~~) → 2 bits
 - 8-PSK → 3 bits
 - 16-QAM → 4 bits
 - 32-QAM → 5 bits
 - 64-QAM → 6 bits

Modulation schemes: PSK

- PSK = Phase Shift Keying
 - Modulate the phase to send information
- CPSK = Phase can encode binary data (need a referential phase signal)
- DPSK = Changing phase can encode binary data (more erroneous demodulation)

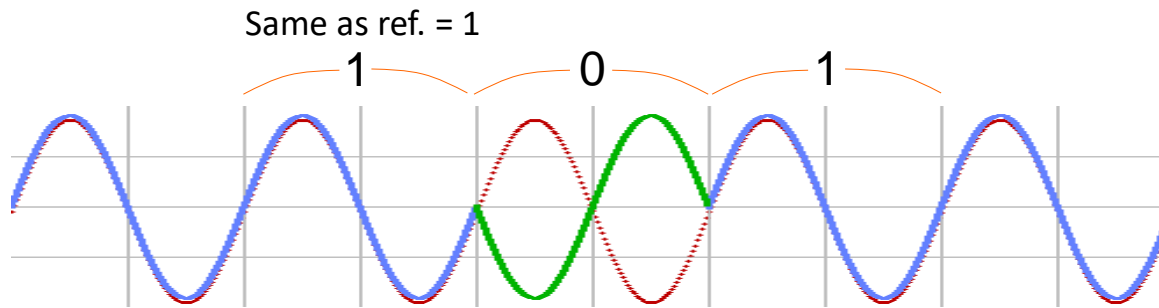

CPSK (in red the reference phase signal)

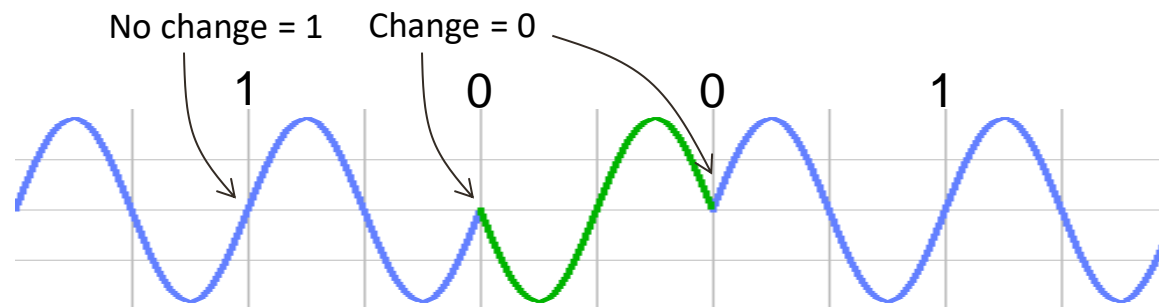

DPSK

Modulation schemes: QPSK

- QPSK = Quadrature PSK (~~Also known as 4-QAM~~)
- With 4 phases QPSK can encode symbols in 2 bits
 - 1 most significant bit and 1 least significant bit
- Most significant bit : $\cos \alpha$
- Least significant bit : $\sin \alpha$

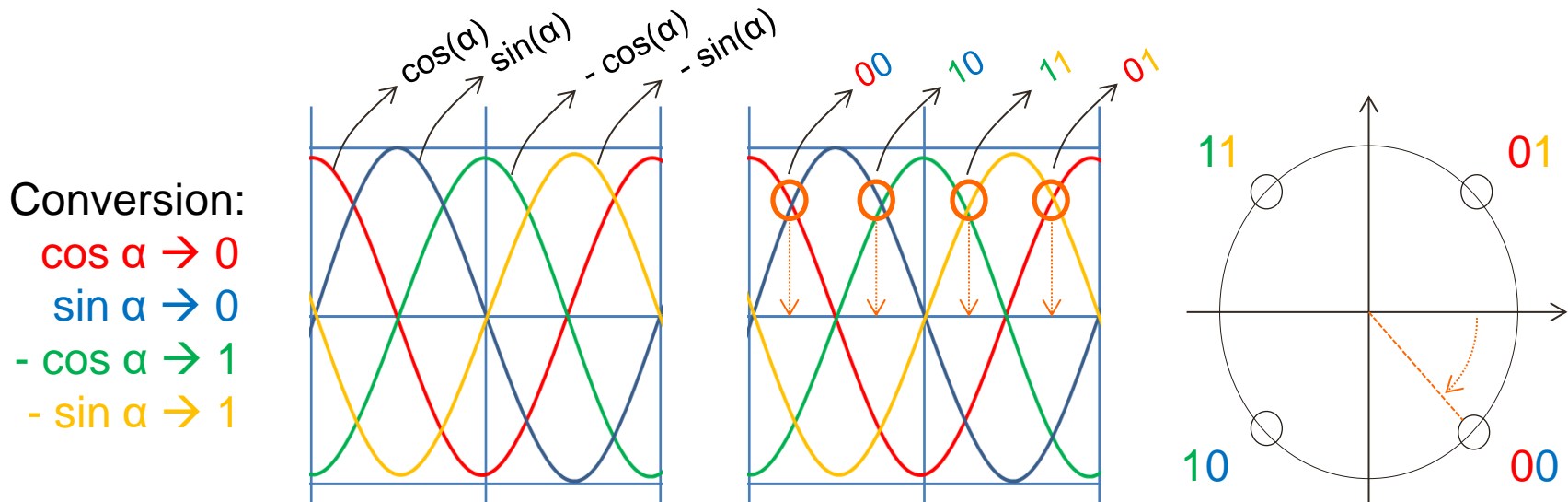

Modulation schemes: QPSK

- Example: bit stream = 010010100100
- Splitting → 01 00 10 10 01 00
- Distribution → cos part: 001100 & sin part: 100010
- NRZ → (-1-1 1 1-1-1) & (1-1-1-1 1-1)

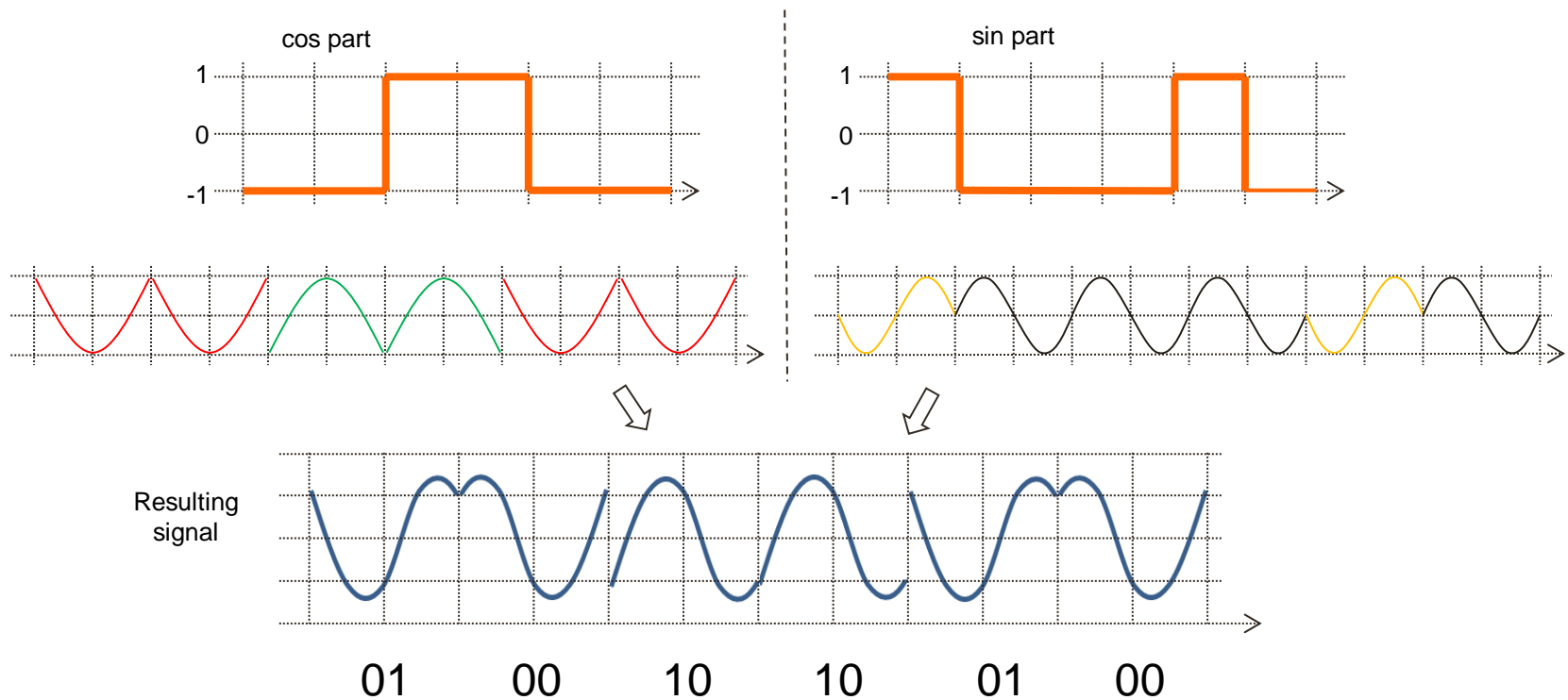

Agenda

- Architecture global view
- LTE frequency domain technologies
- LTE time domain technologies
- Convergence of time and space
- LTE protocol architecture
 - Packet Data Convergence Protocol layer
 - Radio Link Control layer
 - Medium Access Control layer
- Resource Allocation

LTE Architecture: OFDM symbol

- Information is sent within OFDM symbol
- OFDM symbol is the smallest structure in LTE
- OFDM symbol can handle 2 to 6 bits according to the modulation scheme
 - The shape of the sinusoid corresponds to the encoded bits pattern

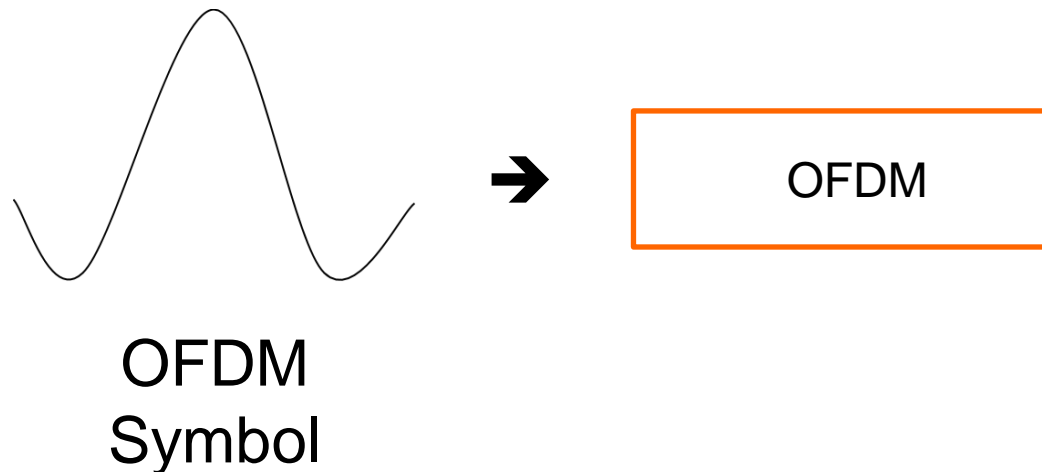

LTE Architecture: Sampling

- 1 OFDM symbol corresponds to operating an IFFT on all sub-carriers sinusoid signals

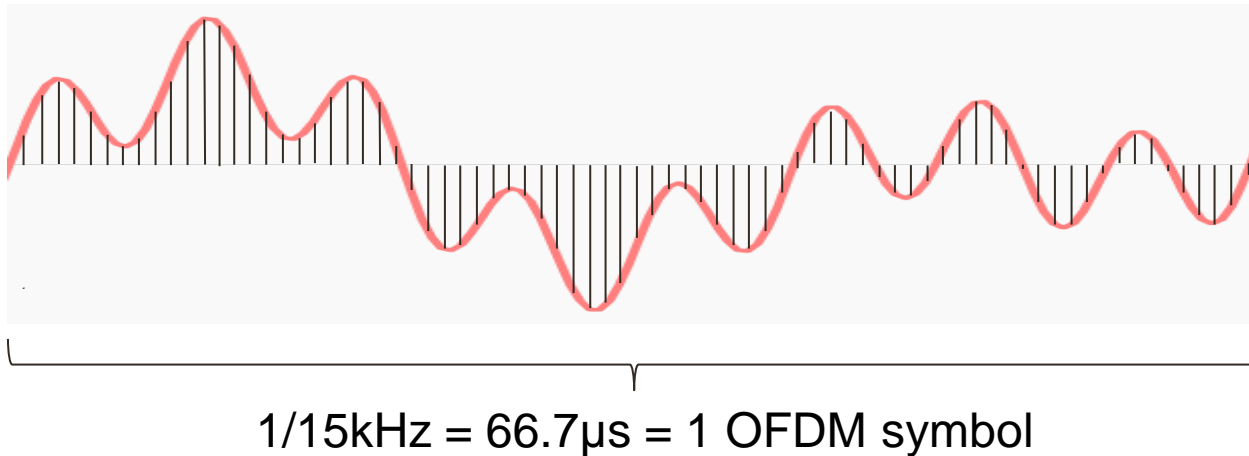

- A signal corresponds to a succession of values in time (sampling)
- Sampling rate (f_s) in LTE is coherent with UMTS sampling rate

$$f_s^{UMTS} = 3.84\text{MHz} = \frac{1}{8} f_s^{LTE}_{20\text{MHz}} \Rightarrow f_s^{LTE}_{20\text{MHz}} = 30.72\text{MHz}$$

LTE Architecture: Sampling

BW (MHz)	1.4	3	5	10	15	20
Number of sub-carriers	72	180	300	600	900	1200
FFT size	128	256	512	1024	1536	2048
UMTS sample rate ratio	2/1	1/1	1/2	1/4	1/6	1/8
Samples per slot	960	1920	3840	7680	11520	15360

LTE Architecture: Time Slot

- OFDM symbols are grouped in Time Slots (TS)
- A Time Slot contains 7 OFDM symbols
- Its duration is 0.5ms

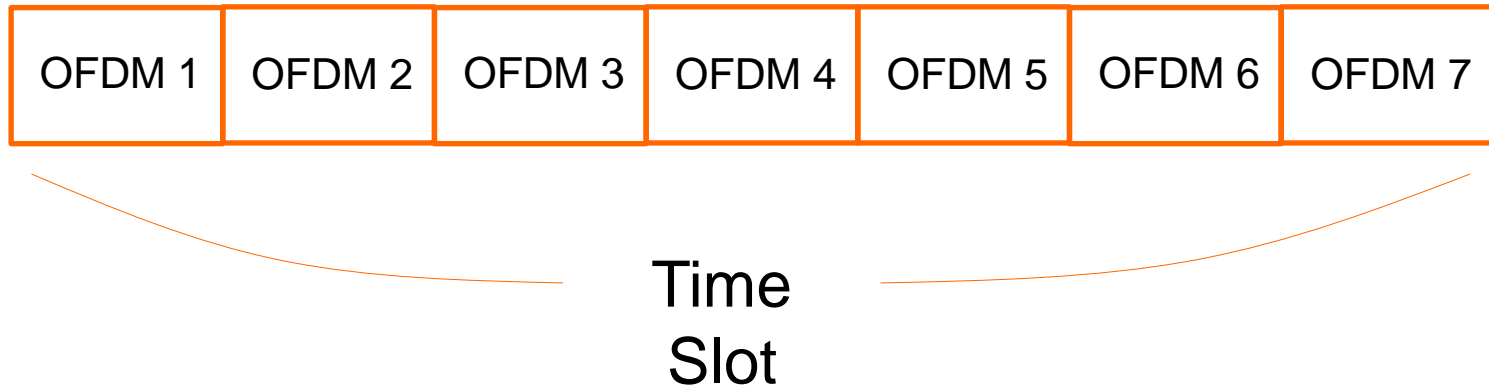

LTE Architecture: Sub-Frame

- Time Slots are grouped in Sub-Frames (SF)
- A Sub-Frame contains 2 Time Slots (14 OFDM)
- Its duration is thus 1ms

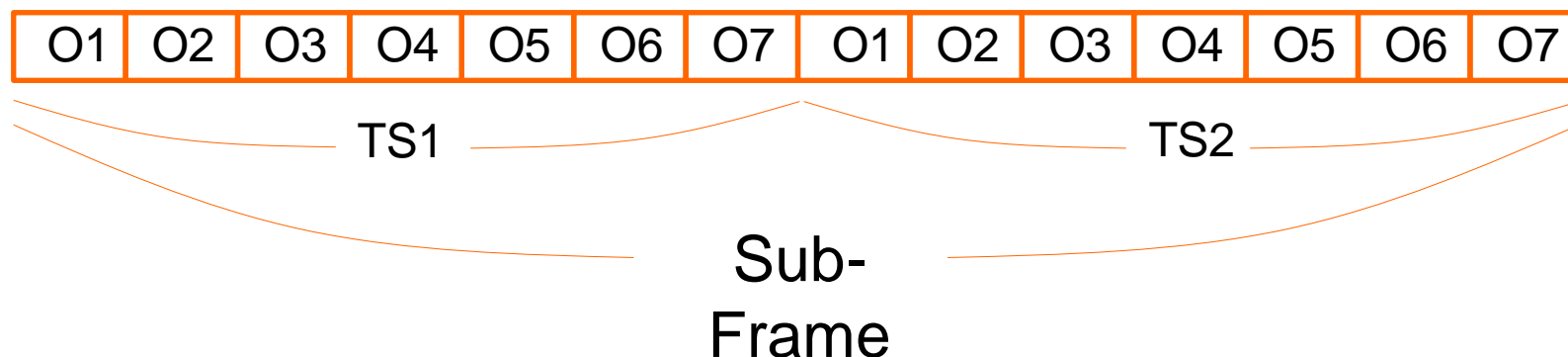

LTE Architecture: Radio-Frame

- Sub-Frames are grouped in Radio-Frames (RF)
- A Radio-Frame contains 10 Sub-Frames (20TS, 140 OFDM)
- Its duration is 10ms



Radio-
Frame

LTE Architecture: Decomposition in time samples

- OFDM symbols are actually composed of samples
- An OFDM symbol is made of two parts, the cyclic prefix and the burst
 - The burst is the part allocated to data
 - The cyclic prefix is acting as a guard band
 - The cyclic prefix is equal to the end of the Burst

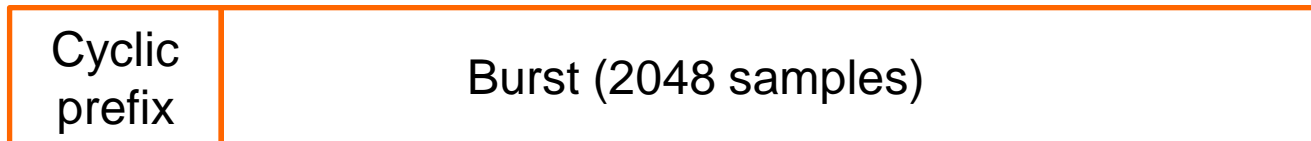

OFDM
Symbol

- 1 OFDM symbol is $66.7 \mu\text{s}$ ($1/15\text{kHz}$)
- At 30.72MHz sampling rate, $66.7\mu\text{s}$ give 2048 samples

LTE Architecture: More on cyclic prefix

- It exists two protocols for the cyclic prefix
- In the normal cyclic prefix mode:
 - The first OFDM symbol of the TS has a cyclic prefix of length 160
 - All the others symbols have a cyclic prefix of 144
- In the extended cyclic prefix mode:
 - Only 6 OFDM symbols per TS
 - All OFDM symbols have a cyclic prefix of length 512
- The normal cyclic prefix is used in urban cells and high data rate applications
- Extended cyclic prefix is used in special cases like multi-cell broadcast and in very large cells (e.g. rural areas, low data rate applications)

LTE Architecture: Summary

- OFDM symbols can be expressed as multiples of the minimal time value ($1 / 30720000$) called a sample (in seconds)
 - The sampling rate vary with bandwidth

- At 20MHz bandwidth, $f_{S_{20MHz}}^{LTE} = 30.72MHz$
 - 100 RF = 2000 TS = 30720000 samples → 1 symbol = 2048 samples
 - Normal cyclic prefix
 - 2208 samples (160 + 2048 samples) for 1st OFDM thus $5.2\mu s + 66.7\mu s = 71.9\mu s$
 - 2192 samples (144 + 2048 samples) for the rest thus $4.7\mu s + 66.7\mu s = 71.3\mu s$
 - Extended cyclic prefix
 - 2560 samples (512 + 2048 samples)

- At 1.4MHz bandwidth $f_{S_{1.4MHz}}^{LTE} = 1.92MHz$
 - Normal cyclic prefix
 - 138 samples (10 + 128 samples) for 1st OFDM thus $5.2\mu s + 66.7\mu s = 71.9\mu s$
 - 137 samples (9 + 128 samples) for the rest thus $4.7\mu s + 66.7\mu s = 71.3\mu s$
 - Extended cyclic prefix
 - 160 samples (32 + 128 samples)

LTE Architecture: Summary

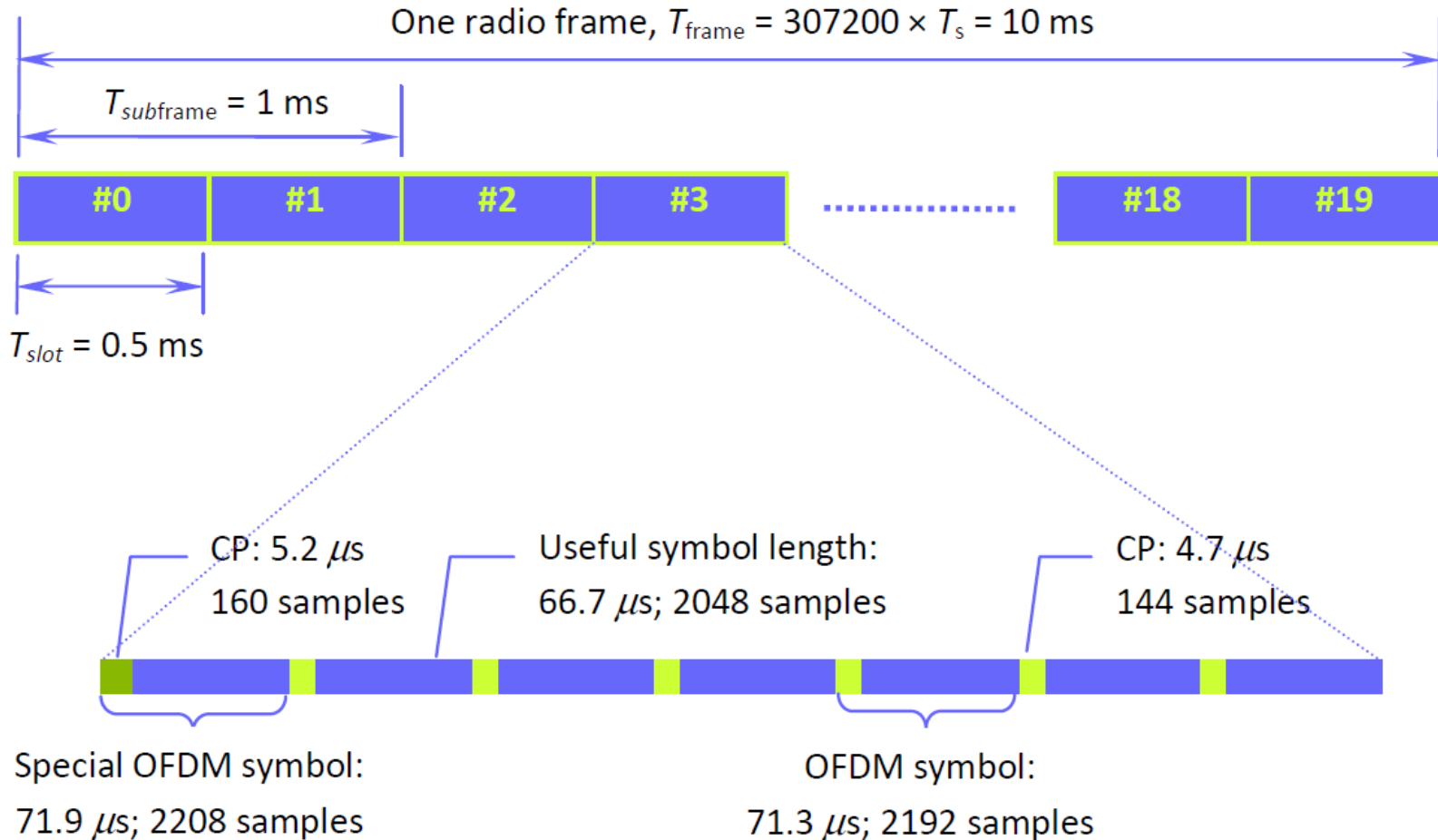

©2010 Telesystem Innovations Inc.

Agenda

- Architecture global view
- LTE frequency domain technologies
- LTE time domain technologies
- Convergence of time and space
- LTE protocol architecture
 - Packet Data Convergence Protocol layer
 - Radio Link Control layer
 - Medium Access Control layer
- Resource Allocation

LTE Principles: Space-time

- LTE technology is the convergence of the frequency separation (OFDM and sub-carriers) and LTE architecture (TS and OFDM symbols)
- Information is sent through several sub-carriers at different Time Slots

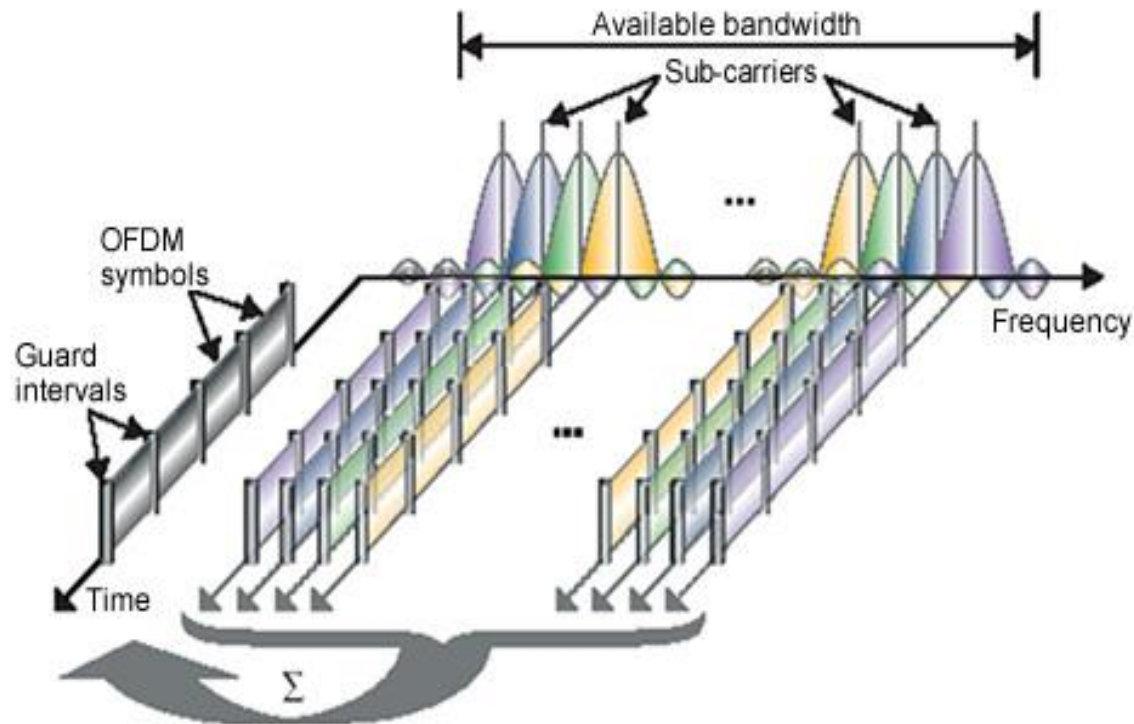

LTE Principles: Minimal Resource

- The minimal LTE resource is called Private Resource Block (PRB)
- One PRB is equal to a resource block (RB) by a time slot
 - i.e. $1\text{RB} \times 1\text{TS} = 12 \text{ sub-carriers} \times 7 \text{ OFDM symbols}$
- The minimal resource available for users is called a Resource Block Pair (RBP). It corresponds to a resource block by a subframe
 - i.e. $1\text{RB} \times 2\text{TS} = 1\text{RB} \times 1\text{SF}$

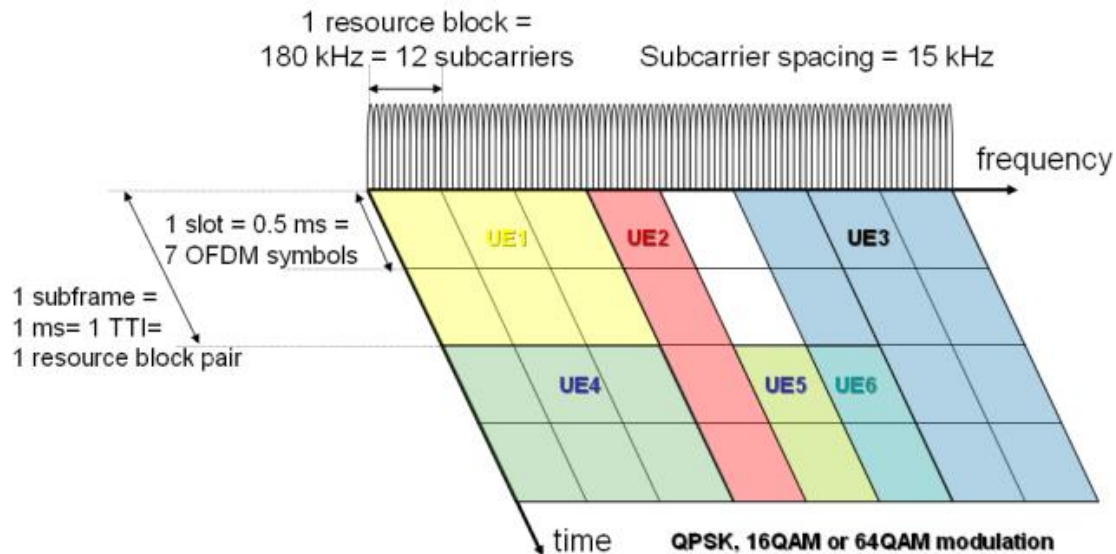

LTE Principles: Resource Blocks

- The number of RB increases with the bandwidth

BW (MHz)	1.4	3	5	10	15	20
Sub-carriers	72	180	300	600	1000	1200
RB	6	15	25	50	75	100

- There are $7 \times 12 = 84$ OFDM symbols inside a PRB
 - 72 in the case of extended cyclic prefix
- Inside a PRB, OFDM symbols are called Resource Elements
- eNodeB informs the user on allocated sub-carriers (RB) and corresponding modulation scheme

LTE Principles: Resource Blocks

Space-time
→ Resource block

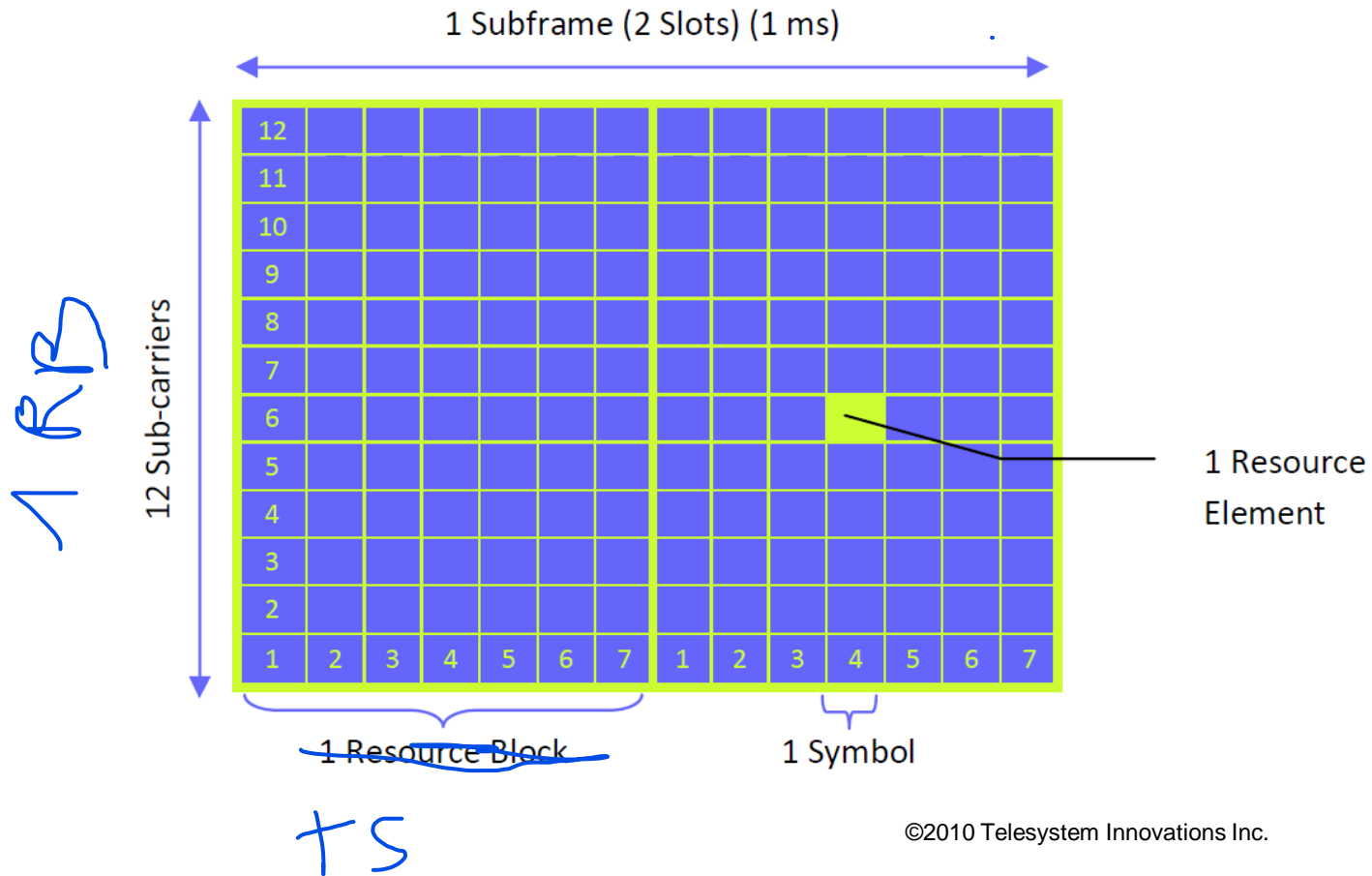

©2010 Telesystem Innovations Inc.

LTE Principles: Resource Blocks

- The UL transmission structure is similar to DL
- The smallest unit resource is the Resource Element
- One resource element is a SC-FDMA data block by a sub-carrier
 - 1 RE = 1 SC-FDMA data block x 1 sub-carrier
 - Thus 1 RB = 12 RE x 1 TS (0.5ms)
- Multiples RB are assigned consecutively in the frequency domain to a UE

Agenda

- Architecture global view
- LTE frequency domain technologies
- LTE time domain technologies
- Convergence of time and space
- LTE protocol architecture
 - Packet Data Convergence Protocol layer
 - Radio Link Control layer
 - Medium Access Control layer
- Resource Allocation

LTE layers & channels

- LTE SAE is made of eUTRAN and EPC
 - The radio protocol is divided into Control Plane Architecture and User Plane Architecture
 - Packets in the core network are encapsulated (IP)
- Control plane protocols includes Radio Resource Control layer
- User plane is made of 3 layers
 - Packet Data Convergence Protocol layer (PDCP)
 - Radio Link Control layer (RLC)
 - Medium Access Control layer (MAC)
- And 3 types of channels
 - Logical, Transport and Physical

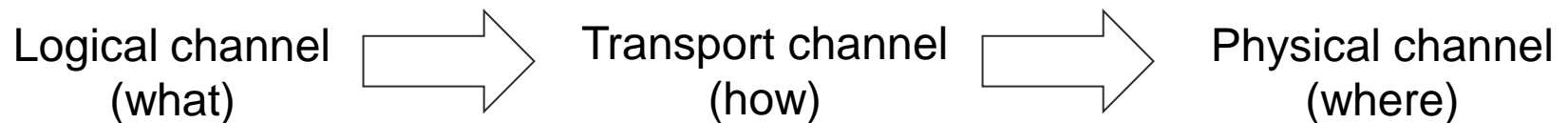

LTE PDCP layer

- Packet Data Convergence Protocol layer
 - Header compression and decompression
 - Handover management
 - Re-orders and sequences PDUs
 - Performs encryption and decryption
 - Cyphers data against eavesdropping (SNOW 3G, AES-128)
 - Ensure data integrity against packet insertion by third party
 - Requires mutual authentication between UE and network

LTE RLC layer

Protocols
→ RLC layer

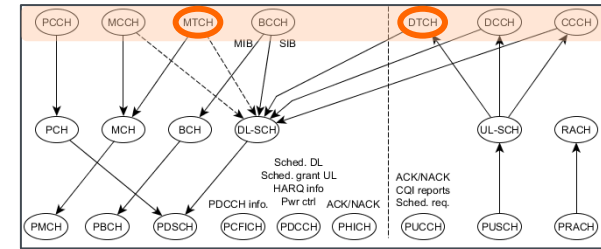

■ Radio Link Control layer (RLC)

- Segments the traffic according to logical data types
- Uses logical channels

■ RLC uses 2 logical traffic channels

- Nomenclature: TCH means Traffic Channel
- DTCH (Dedicated) (UL & DL)
 - Carries users traffic data
- MTCH (Multicast) (DL)
 - Carries information for broadcast, real-time broadcast (sports, events, etc.)

LTE RLC layer: Logical channels

Protocols
→ RLC channels

■ RLC uses 5 logical control channels

- Nomenclature: CCH means Control CHannel
- PCCH (Paging) (DL)
 - When UE is in idle mode, used to notify user of incoming call or change in system configuration
- BCCH (Broadcast) (DL)
 - Bandwidth information, antenna configuration, reference signal power, etc.
- CCCH (Common) (UL)
 - When the UE is switched on and wants to catch the network without radio resources to establish a radio connection
- DCCH (Dedicated) (UL & DL)
 - Carries setup and resources allocated to users. Transfers control information
- MCCH (Multicast) (DL)
 - Broadcasts control information for a group of user in the same cell

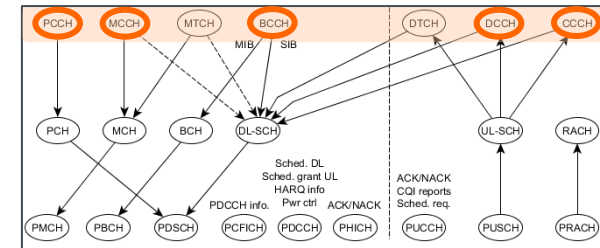

LTE MAC layer

- Medium Access Control (MAC)
 - Is the brain of LTE
 - Maps logical channels to transport channels (multiplexing)
 - Logical channels prioritization
 - HARQ retransmission (Hybrid Automatic Repeat Request)
- MAC control
 - Decides modulation schemes based on CQI reports
 - Aligns uplink timing
 - Manages paging information
 - Manages terminals to transmit
 - Manages transport blocks

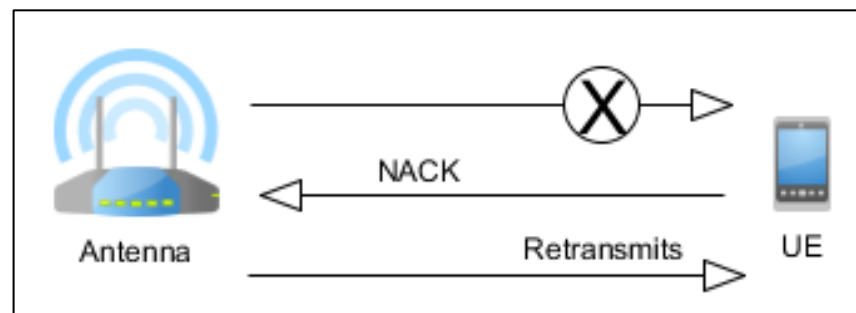

HARQ protocol

LTE MAC layer: Transport channels

Protocols
→ MAC channels

■ MAC controls 6 transport channels

- PCH (Paging) (DL)
- BCH (Broadcast) (DL)
 - Essential to decode DL-SCH
- DL-SCH (Downlink Shared)
 - Transports downlink user data or control messages
- UL-SCH (Uplink Shared)
 - Transports uplink user data
- MCH (Multicast)
- RACH (Random Access)
 - Initiated for UL synchronization with antenna, or when it has no accurate uplink timing synchronization

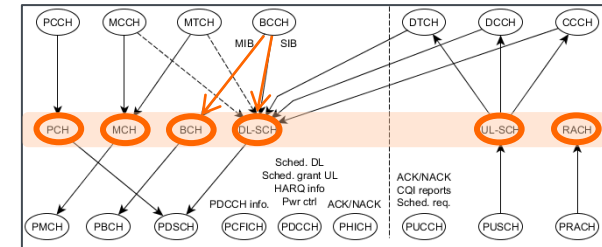

■ Logical channel BCCH is made of 2 parts

- MIB (Master Information Block)
 - Contains system critical information to acquire the cell
 - Goes to BCH transport channel
- SIB (System Information Block)
 - Contains dynamic information to access the cell
 - UE is still unaware of resources alloc. → need to decode MIB first
 - Goes through DL-SCH transport channel

LTE MAC layer: Channels mapping

- MAC layers ensures multiplexing of logical channels to transport channels
- Links the transport channel with physical channels
 - Physical channels are mapped on resource blocks

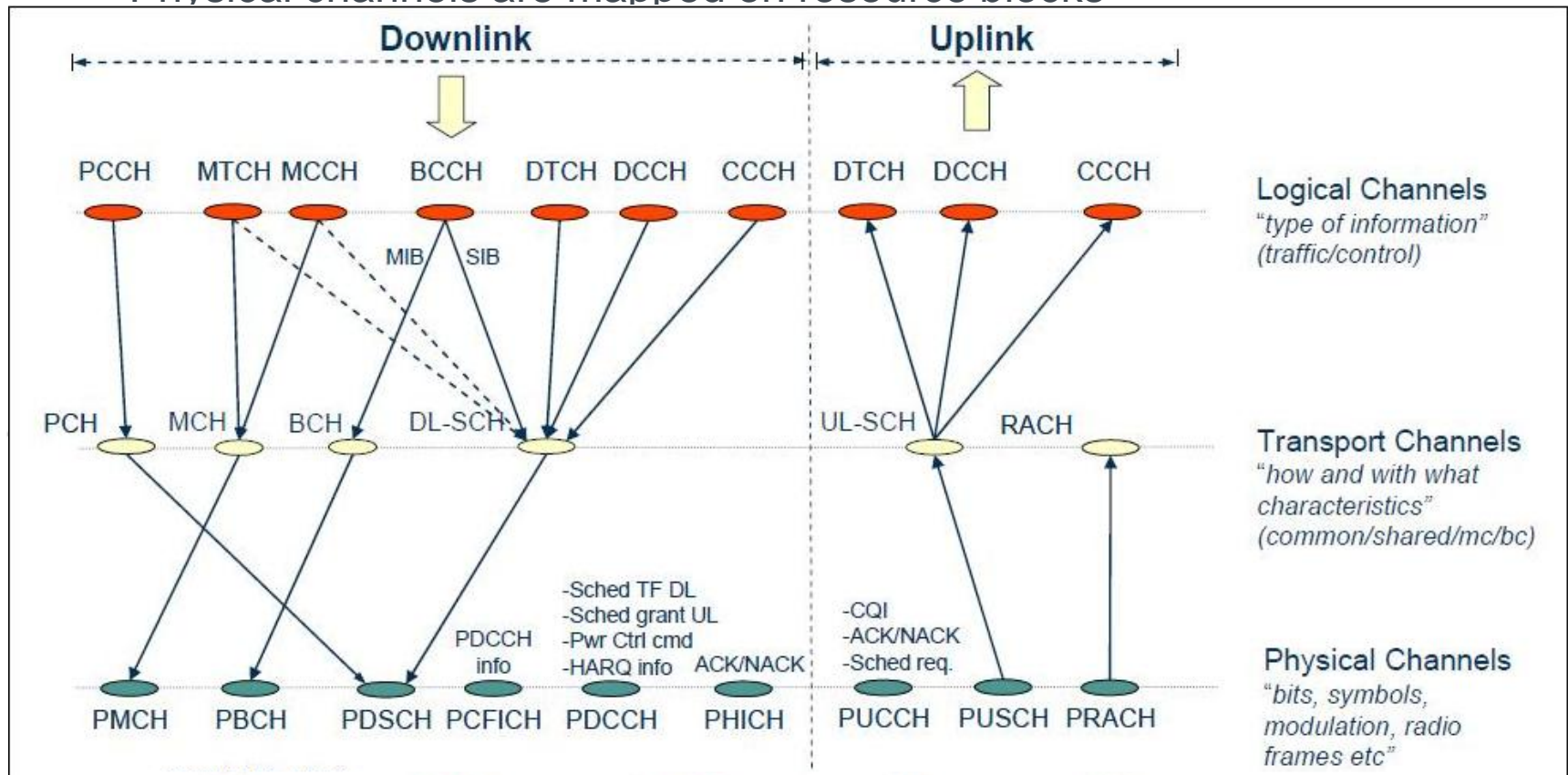

LTE Channeling example

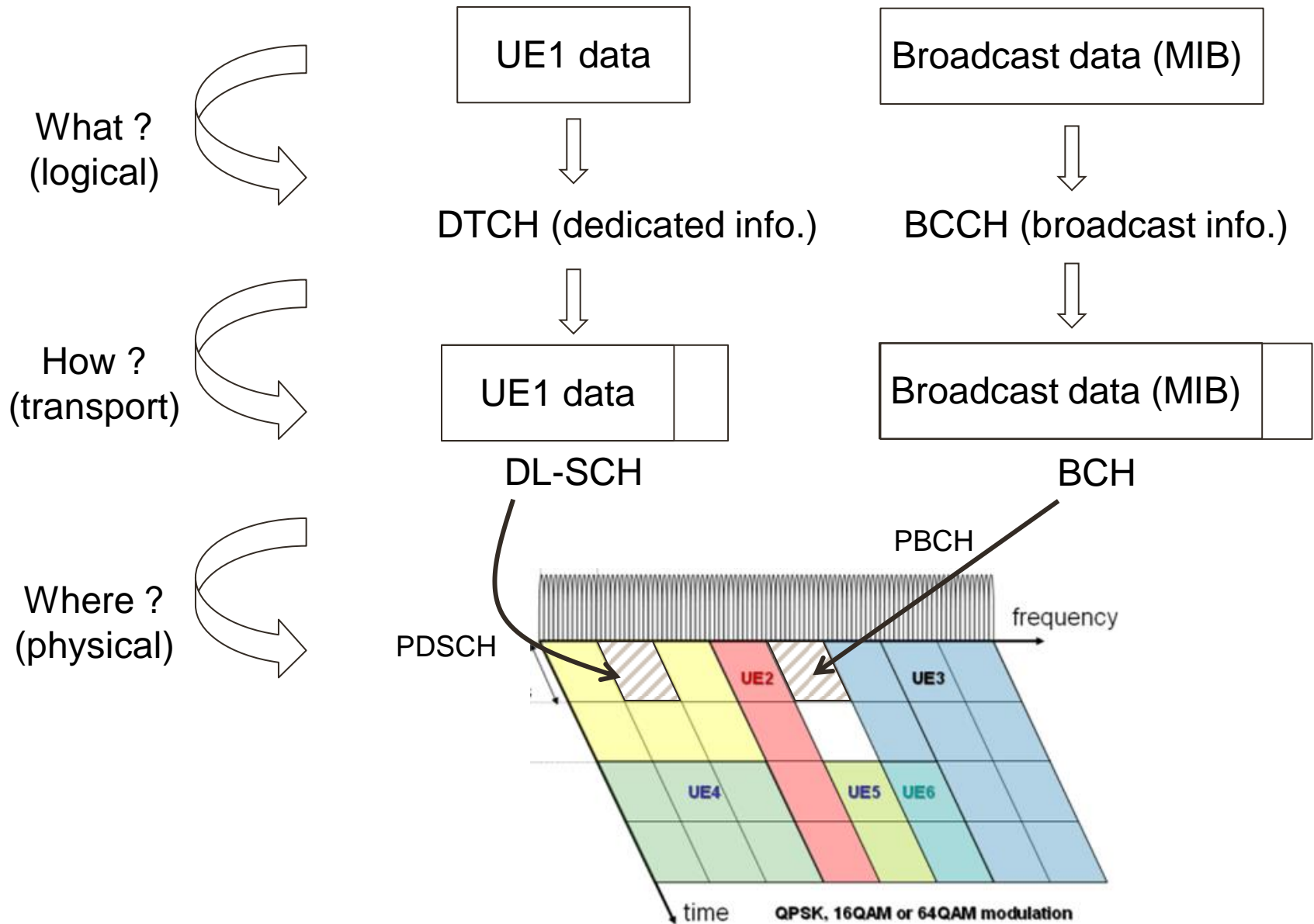

LTE MAC layer: Physical channels

Protocols
→ Physical channels view

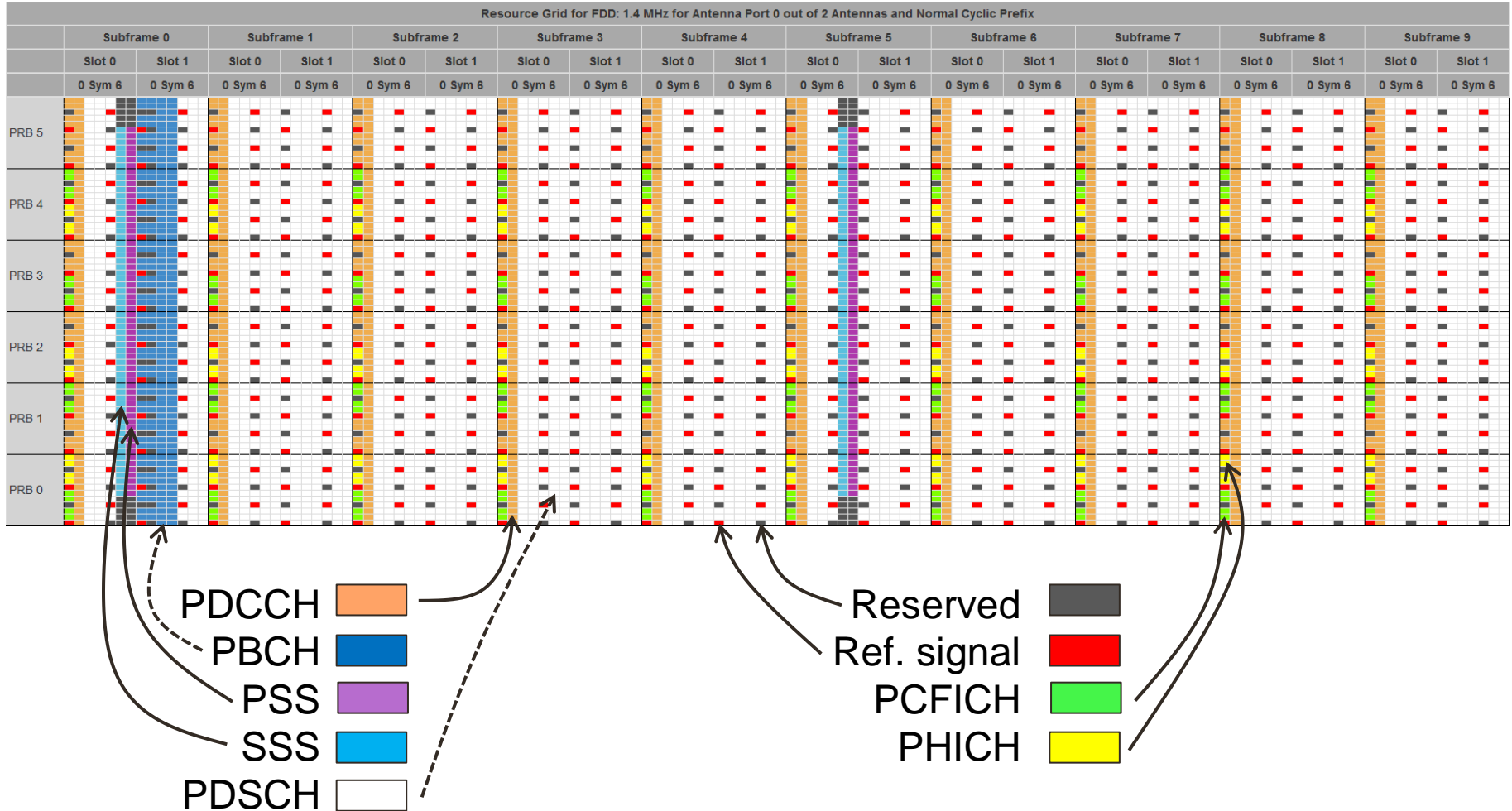

LTE MAC layer: Reference Signals DL

Protocols
→ Reference
signals

- To allow a coherent demodulation at the UE, reference symbols (or pilot symbols) are inserted in the OFDM time-frequency grid
- Downlink reference symbols are inserted within the first and third last OFDM symbol of each slot with a frequency domain spacing of six sub-carriers
- The first and second reference symbols are also separated by three sub-carriers
- The user equipment will interpolate over multiple reference symbols to estimate the channel quality (CQI)

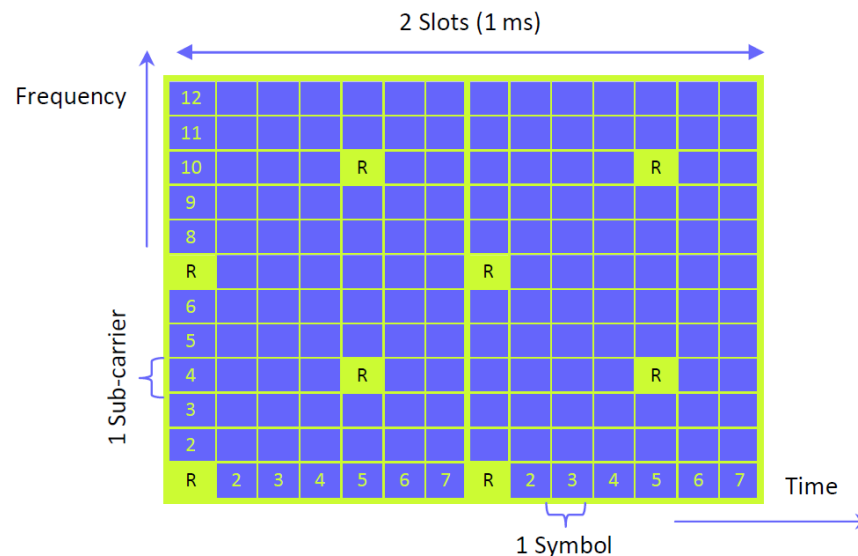

LTE MAC layer: Reference Signals UL

Protocols
→ Reference
signals

- There are two types of reference signals for uplink in LTE
- Demodulation Reference Signals (DM-RS) are used to enable coherent signal demodulation at the eNodeB
 - Time multiplexed with uplink data
 - Transmitted on the fourth or third SC-FDMA symbol of an uplink slot for normal or extended CP
 - Uses the same bandwidth as the data.
- Sounding Reference Signal (SRS) is used to allow channel dependent uplink scheduling

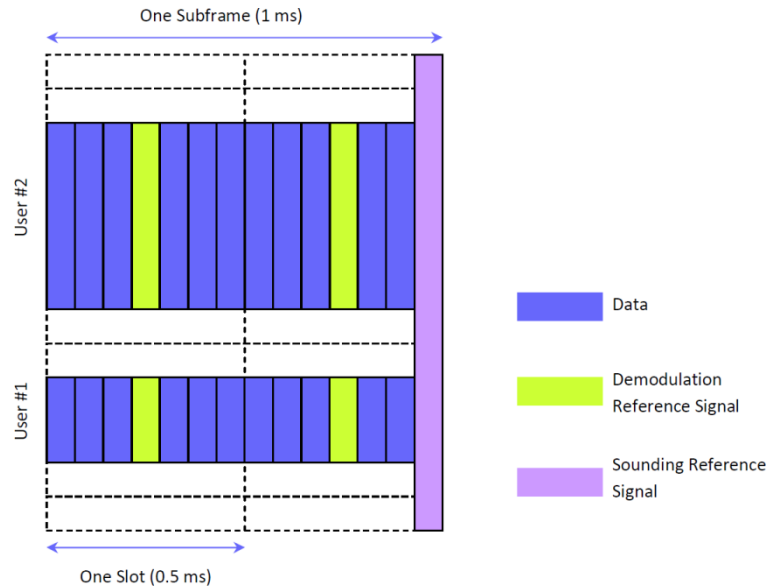

LTE MAC layer: Synchronization sequences

- A UE follows a cell search procedure which includes a series of synchronization stages
 - Determines time and frequency parameters
 - Necessary for demodulating downlink signals
 - Necessary for transmitting with correct timing and for acquiring system parameters
- There are three synchronization sequences in LTE
 - Symbol timing acquisition (the correct symbol start is determined)
 - Carrier frequency synchronization (mitigates the effect of frequency errors resulting from Doppler shift and electronics errors)
 - Sampling clock synchronization

LTE MAC layer: Cell Search Procedures

- There are two cell search procedures in LTE
 - Initial synchronization
 - Detection of neighbor cells in preparation for handover
- The UE uses two special signals broadcast on each cell
 - Primary Synchronization Sequence (PSS)
 - Secondary Synchronization Sequence (SSS)
- The detection of these signals allows the UE to complete time and frequency synchronization
- Necessary for acquiring useful system parameters
 - cell identity
 - cyclic prefix length,
 - access mode (FDD/TDD)

LTE MAC layer: Cell Search Procedures

- Synchronization signals are transmitted twice per 10 ms (Radio Frame)
- The PSS is located in the last OFDM symbol of the first and 11th slot of each radio frame
 - Allows the UE to acquire the slot boundary timing independent of the type of cyclic prefix length
 - The PSS signal is the same for any given cell in every subframe in which it is transmitted
 - The PSS uses a sequence known as Zadoff-Chu
- The SSS is located in the before to last symbol of the first and 11th slot of each radio frame
 - the SSS uses a sequence known as M-sequences

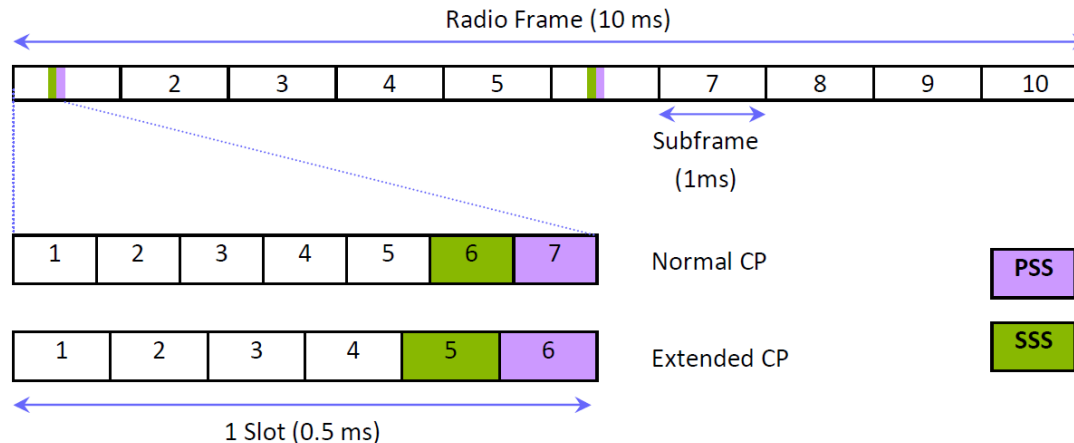

LTE MAC layer: Physical Channels

- LTE defines 6 DL physical channels to carry information blocks received from the MAC and higher layers
- DL Transport Channels
 - PBCH = Physical Broadcast Channel
 - PDSCH = Physical Downlink Shared Channel
 - PMCH = Physical Multicast Channel
- DL Control Channels
 - PDCCH = Physical Downlink Control Channel
 - PCFICH = Physical Control Format Indicator Channel
 - PHICH = Physical Hybrid ARQ Indicator Channel
- LTE defines three UL physical channels
 - PUSCH = Physical Uplink Shared Channel
 - PUCCH = Physical Uplink Control Channel
 - PRACH = Physical Random Access Channel

Physical Broadcast Channel

Physical Channels
→ PBCH

- Broadcasts a limited number of parameters essential for initial access of the cell
 - Downlink system bandwidth
 - PHICH structure
 - Most significant eight-bits of the System Frame Number
- These parameters are carried in a Master Information Block (14 bits)
- The MIB is coded at a very low coding rate and mapped to the 72 center sub-carriers of the OFDM structure
- PBCH transmission is spread over four Radio Frames to span a 40 ms period
- The PBCH is transmitted using Space Frequency Block Code (SFBC)

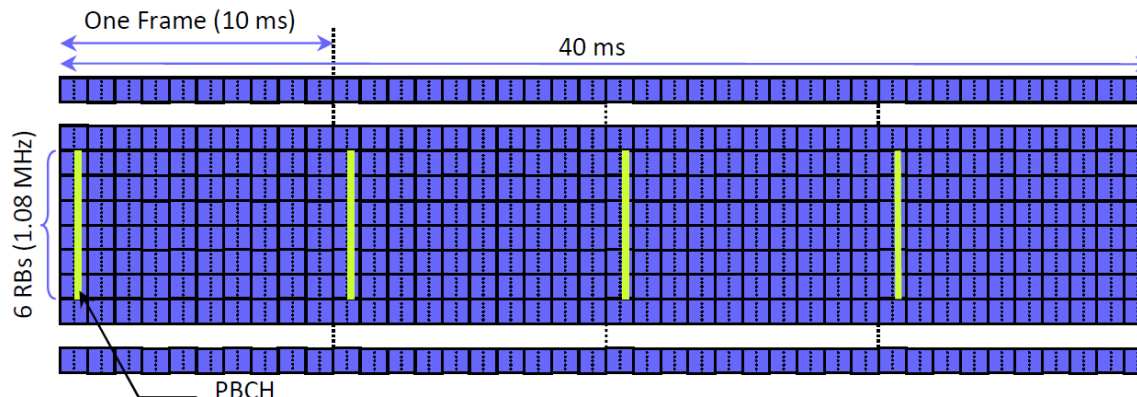
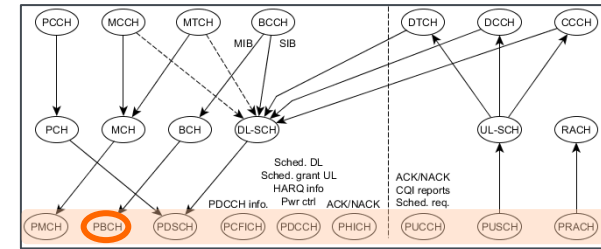

Physical Downlink Shared Channel

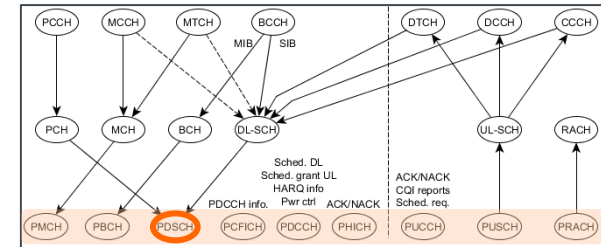

- Main data bearing channel
 - Allocated to users on a dynamic and opportunistic basis (Resource Allocation)
 - Carries data on a Transport Block (TB) which correspond to a MAC PDU
 - Passed from the MAC layer to the PHY layer once per Transmission Time Interval (TTI) which is 1 ms
- Physical resources are assigned on a basis of two resource blocks for one TTI
 - Known as ‘pair of resource blocks’ which is the quantum of resources that can be allocated
 - Corresponds to 12 sub-carriers (180 kHz) for 14 OFDM symbols
- Contains paging information

Physical Downlink Control Channel

Physical Channels
→ DCCH

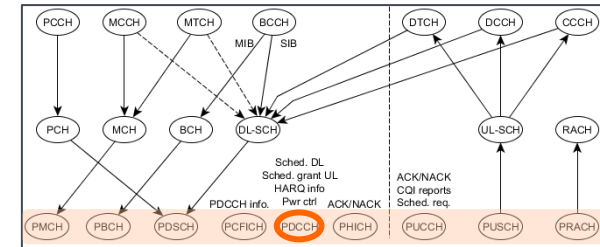

- Carries the resource assignment for UEs
 - Contained in a Downlink Control Information (DCI) message
- Holds control info. about SIB needed to transmit UL data
- Used for HARQ info.
- Used for power control info.
- Multiple PDCCHs can be transmitted in the same subframe
- Uses QPSK modulation

Other DL channels

Physical Channels
→ Others

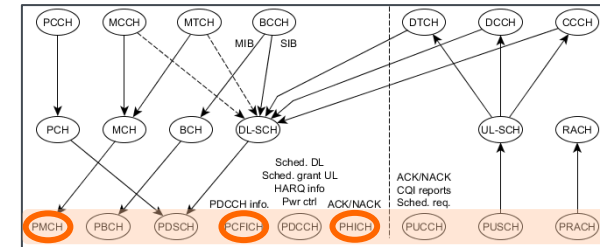

■ Physical Multicast Channel

- Defines the physical layer structure to carry Multimedia Broadcast and Multicast Services (MBMS)

■ Physical Control Format Indicator Channel

- Carries the Control Frame Indicator (CFI) which includes the number of OFDM symbols used for PDCCH in each subframe (typically 1, 2, or 3)
- Contains the format of the signal

■ Physical Hybrid ARQ Indicator Channel

- Carries the HARQ ACK/NAK which indicates to the UE whether the eNodeB correctly received uplink user data

Physical Uplink Shared Channel

Physical Channels
→ PUSCH

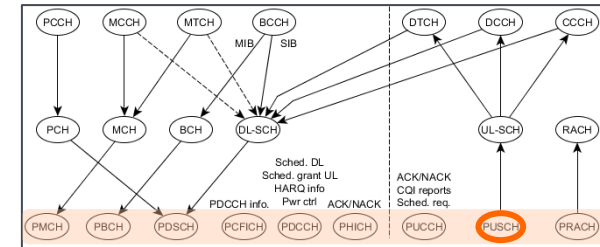

- Carries user data
 - Supports QPSK and 16 QAM modulation
- Adjacent data symbols are mapped to adjacent SC-FDMA symbols in the time domain before being mapped across sub-carriers
- The uplink scheduling interval is 1 ms
 - Possible to 'bundle' a group of 4 TTIs to improve performance
 - The MAC PDU is segmented for transmission over multiple TTIs
- Carries also control information
 - Transport format indicators
 - MIMO parameters

Physical Uplink Control Channel

Physical Channels
→ PUCCH

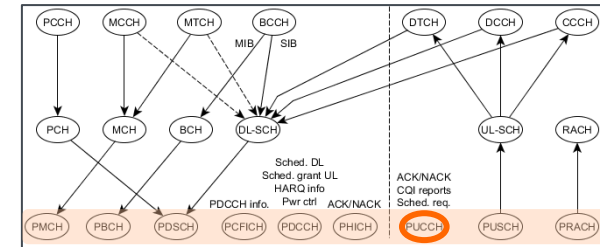

- Transmit signaling data
 - HARQ ACK/NACK
 - Channel quality indicators (CQI)
 - MIMO feedback (Rank Indicator, RI; Precoding Matrix Indicator, PMI)
 - Scheduling requests for uplink transmission
- This channel transmits in a frequency region at the edge of the system bandwidth
- No corresponding transport channel
- Acts as PDCCH for UL

Physical Random Access Channel

Physical Channels
→ PRACH

- Carries the random access preamble that a UE sends to access the network in non-synchronized mode
- Allows the UE to synchronize timing with the eNodeB
- Consists of 72 sub-carriers in the frequency domain
- It exists 4 different Random Access Preamble formats

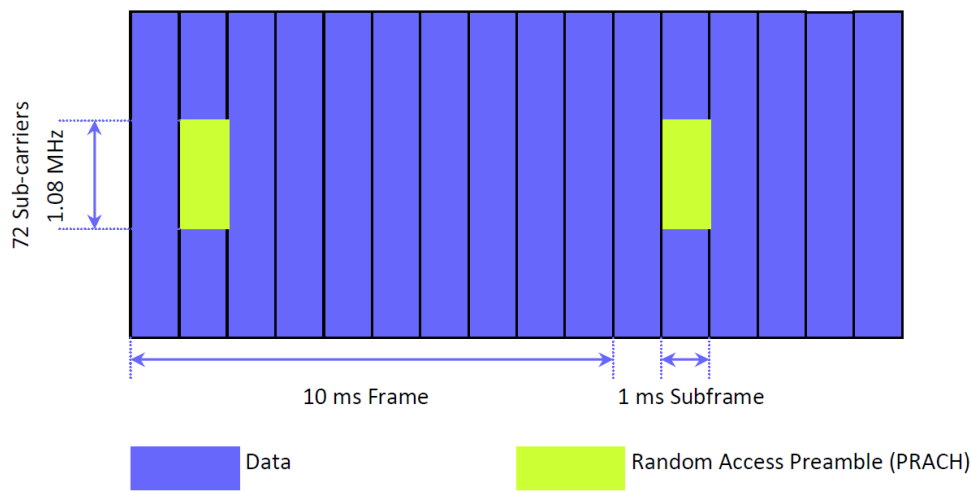
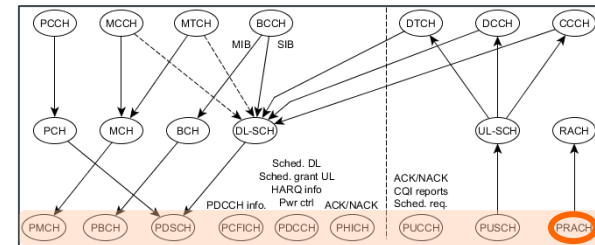

Agenda

- Architecture global view
- LTE frequency domain technologies
- LTE time domain technologies
- Convergence of time and space
- LTE protocol architecture
 - Packet Data Convergence Protocol layer
 - Radio Link Control layer
 - Medium Access Control layer
- Resource Allocation

LTE Principles: Resource Allocation Types

- The allocation of resources for different users in the bandwidth in LTE is done by a Resource Allocation Type (RAT)

Resource Allocation		Purpose	DCI Format
DL Scheduling	Type 0	Resource Block Group (RBG) based	1
		RBG based (MIMO : Closed Loop)	2
		RBG based (MIMO : Open Loop)	2A
	Type 1	Selected RBG Subset based	1
		Selected RBG Subset based (MIMO : Closed Loop)	2
		Selected RBG Subset based (MIMO Open Loop)	2A
	Type 2	VRB based Compact Scheduling + Random Access	1A
		VRB based Compact Scheduling with MIMO	1B
		VRB based Very Compact Scheduling	1C
		VRB based Compact Scheduling with MIMO & Power Offset	1D
UL Scheduling		VRB based UL Scheduling	0

LTE Principles: Resource Allocation

- The UE interprets the resource allocation field depending on the PDCCH (Physical Downlink Control Channel) Downlink Control Information (DCI) format detected
- In RAT 0, allocation happens in terms of RBG (Resource block group)
- 1RBG = n consecutive RB
- The size of a RBG increases with the bandwidth

BW (MHz)	1.4	3	5	10	15	20
Sub-carriers	72	180	300	600	1000	1200
RB	6	15	25	50	75	100
RBG	1	2	2	3	4 (for RB>64)	4

LTE Principles: Resource Allocation

Resource
Allocation
→ Algorithms

- The correlation between the resource field (RBG layer) and the physical layer (OFDMA) is done with a mapper
- A scheduler is used with the mapper to allocate resources to each UE
- Different physical channels are implemented to carry specific and user data
- It exists several scheduling algorithms
 - Round-robin
 - Maximum Channel Quality Indicator
 - Proportional fair (best average repartition)

